

Light Crane Systems & Jib Cranes

Product Catalogue

Technical Information
Component Specification



NIKO ... Quality in Motion

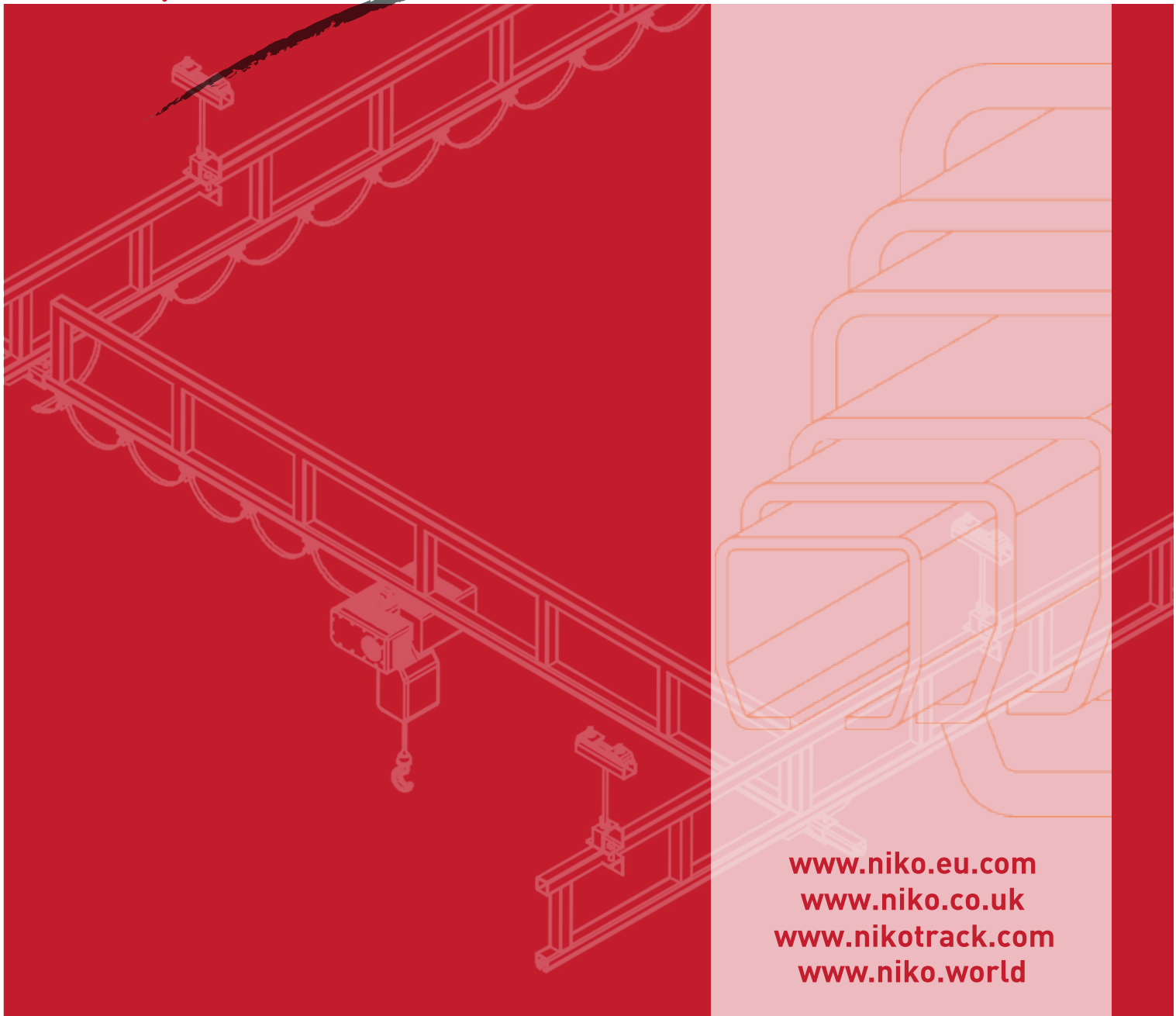

www.niko.eu.com
www.niko.co.uk
www.nikotrack.com
www.niko.world

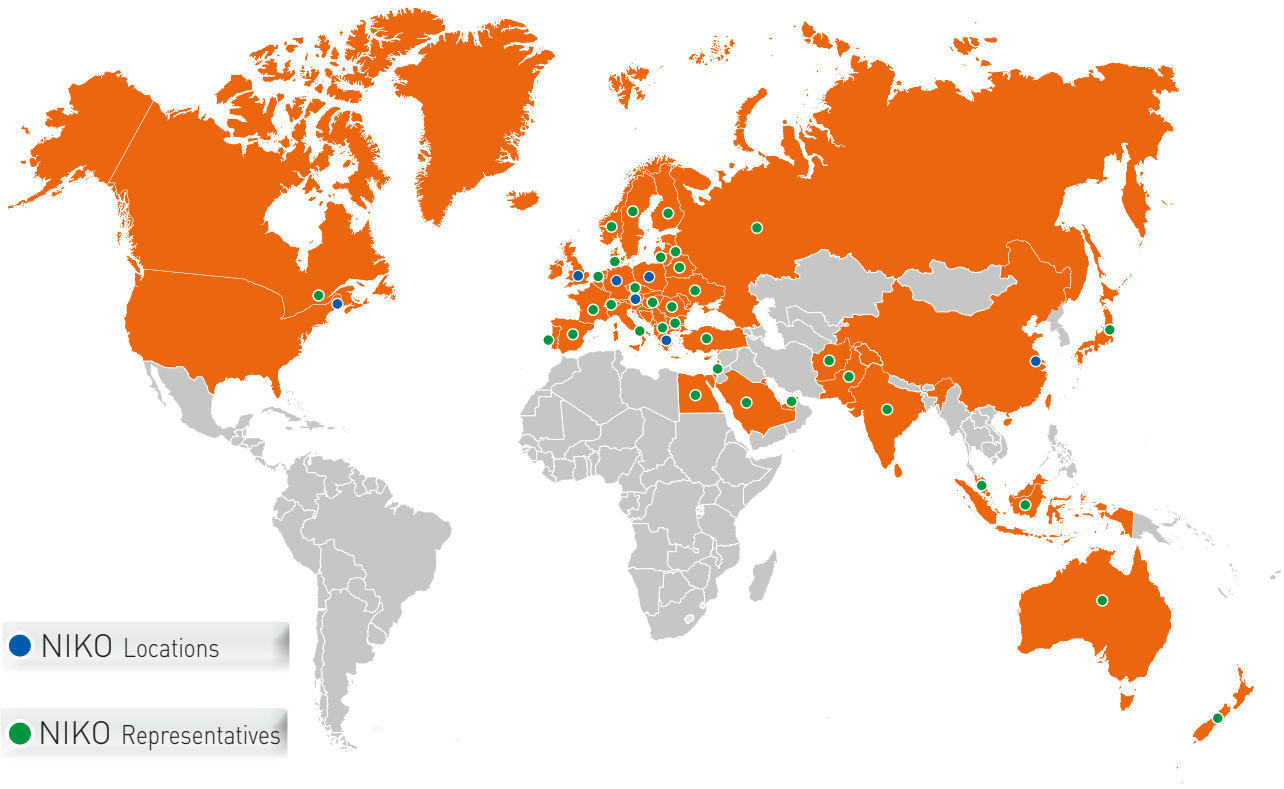

- NIKO Locations
- NIKO Representatives

Company Profile

Established in 1972, NIKO is focused on designing developing, producing and marketing high quality sliding door fittings and overhead conveyor systems at the right price. NIKO currently has a direct presence at seven locations (Greece, Germany, Austria, United Kingdom, Poland , China and U.S.A.), and indirectly through representatives and agents in most European countries, North Africa, Asia and Australia.

Our product range includes more than 2.000 different assemblies & components. Our team of highly qualified engineers are continually working to improve our current product portofolio & extend it according to market requirements.

NIKO enforces a continuous quality control program and is certified according to ISO:9001 and ISO:14001.

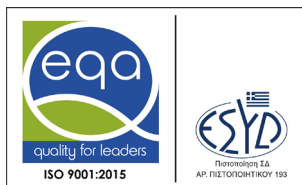

Contents

Application photos	Page	4-5
Introduction	Page	6
Light crane specifications	Page	7
Applications for light cranes	Page	8-9
Multiple bridge cranes	Page	10
Stainless steel light crane 304/316	Page	11
Festoon and conductor options	Page	12
Power driven trolleys	Page	13
Control panel & pendant/radio remote control	Page	14-15
Electric chain hoist	Page	16
Cables	Page	17
Telescopic monorail and cranes	Page	18
Interlocks and manipulators	Page	19
Conveyor system	Page	20
Jlb cranes & components for jib cranes	Page	21-27
Track Profiles	Page	28-29
Brackets and joint supports	Page	30-47
Bearing options	Page	47
Trolleys	Page	48
Load carriers & end carriages	Page	49-53
Bridge interlocks & Track transfer assembly	Page	54-55
Track end stops	Page	56
Cable trolleys	Page	57
Stainless steel product range 304/316	Page	58-62

Application Photos



LIGHT CRANE SYSTEMS

Light crane systems

We reserve the right for technical amendments without obligation.
The product pictures and drawings depicted in this catalogue do not always reflect all available sizes.

Application Photos

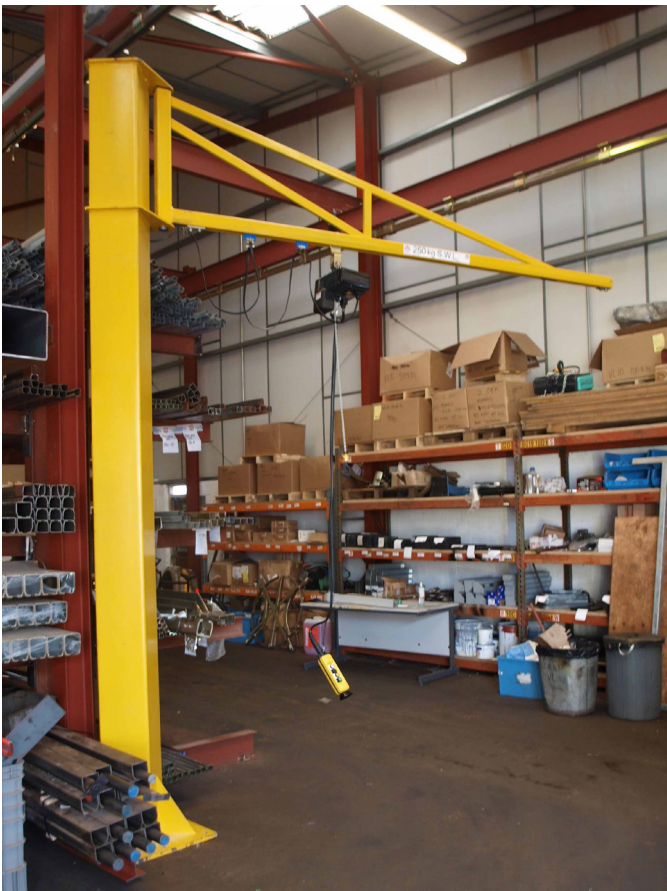

LIGHT CRANE SYSTEMS

Light crane systems

We reserve the right for technical amendments without obligation.
The product pictures and drawings depicted in this catalogue do not always reflect all available sizes.

Version January 2018

www.niko.eu.com

NIKO light cranes – a versatile and economic solution for loads up to 2.000 kg and 10 meter bridge length

NIKO Light Crane System provides an ergonomic and cost effective solution to conventional overhead crane systems, particularly when there is a height and space restriction. Versatile and reliable overhead handling can be achieved for a variety of applications using the NIKO modular design. The robust design of our components and the high standard of manufacturing guarantees long life with the minimum of maintenance. Our product range consists of sliding door fittings, overhead conveyor systems, festoon systems, fall arrest systems and light cranes.

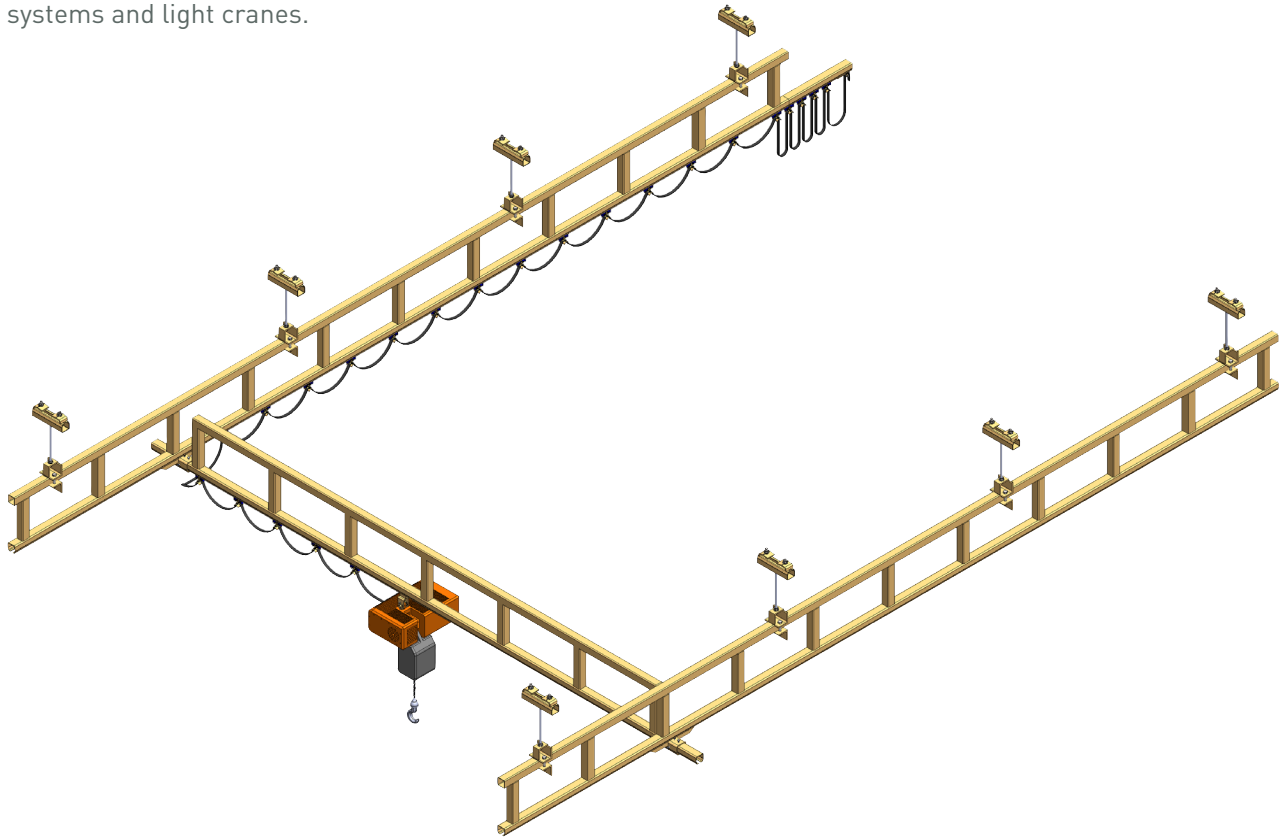

Main Characteristics

- ✓ Loads up to 2.000 kg
- ✓ Bridge spans up to 10 meters.
- ✓ Modular design enables extension, modification and relocation.
- ✓ Cost effective.
- ✓ Easy to install using a variety of supporting brackets.
- ✓ Large range of mounting options.
- ✓ Latching capability enables interconnection with existing or new conveyor or monorail systems.
- ✓ Telescopic cranes.
- ✓ Manual or electric travel
- ✓ Freestanding or ceiling mounted cranes.
- ✓ Gold/silver zinc or powder coated finish.
- ✓ Cranes available in stainless steel.

Advantages over I-beam cranes

- ✓ Small track profiles suitable for lower headroom spaces.
- ✓ Rigid construction which allows steadier travel of loads, more accurate load positioning and no crabbing on the bridge travel.
- ✓ Meter for meter Niko track profiles are light therefore they inflict a lower dead load on the supporting structure and easier to handle when installing.
- ✓ Very low friction which makes it much easier to push the load.
- ✓ Less force to move crane, which achieves better movement and increased productivity.
- ✓ Enclosed track profile design prevents dust from piling up and obstructing the rolling of wheels.

In case standard products do not meet your needs, we have the capability to design and supply bespoke solutions.

Light crane systems

We reserve the right for technical amendments without obligation.
The product pictures and drawings depicted in this catalogue do not always reflect all available sizes.

Light crane specifications

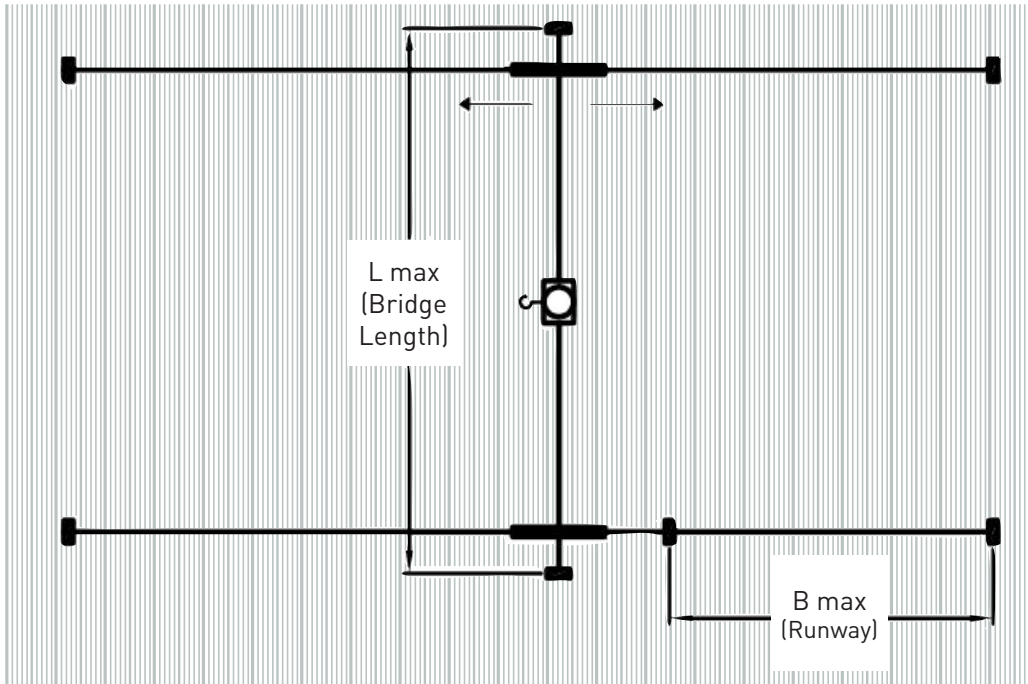

Capacity (Kg)	NIKO Profile No.	Bridge Length L max (m)	Runway supporting distance B max (m)
80	23.000	1.50	1.00
	23.030	4.00	3.50
125	24.000	1.80	1.40
	24.030	5.00	4.40
	24.031	6.00	5.20
	24.080	7.00	6.40
250	24.045	9.00	8.00
	25.000	2.50	1.80
	25.030	6.00	5.20
	25.080	8.00	7.00
500	25.045	10.00	9.00
	26.000	2.50	1.80
	26.030	6.00	5.20
750	26.080	8.00	7.00
	26.045	10.00	9.00
	26.000	1.80	1.00
	26.031	6.00	5.00
1000	26.081	8.00	7.00
	26.045	10.00	9.00
	27.000	3.00	2.00
	27.030	6.00	5.00
1600	27.080	8.00	7.00
	27.045	10.00	9.00
	27.000	1.50	1.00
	27.030	3.50	2.70
2000	27.080	6.00	5.00
	27.045	10.00	9.00
	27.080	5.00	4.00
	27.045	10.00	8.00

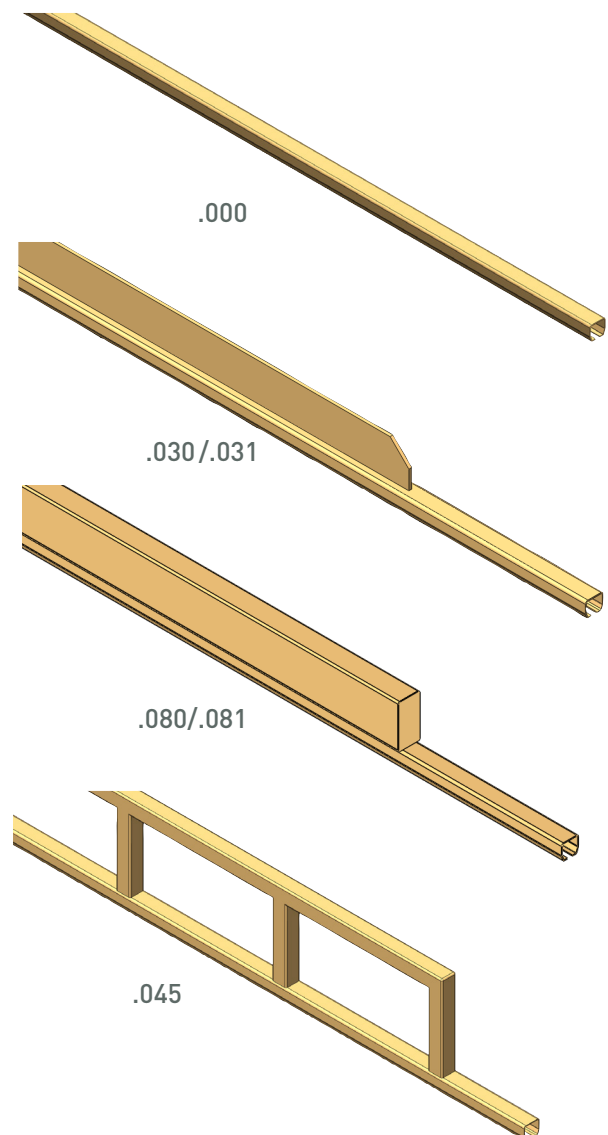

LIGHT CRANE SYSTEMS

Light crane systems

We reserve the right for technical amendments without obligation.
The product pictures and drawings depicted in this catalogue do not always reflect all available sizes.

Freestanding crane with un-reinforced runway tracks

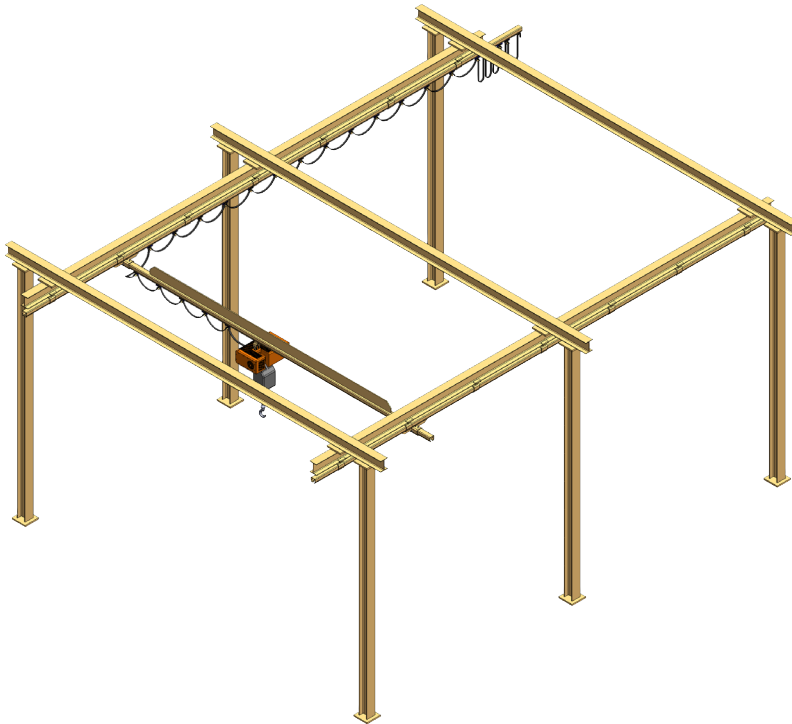

Freestanding cranes are particularly useful when the roof cannot support an overhead crane.

The bridge profile is usually reinforced to achieve longer spans and un-reinforced runway track profiles can be used by supporting them directly to an I beam that runs parallel above.

Freestanding crane with reinforced long travel tracks

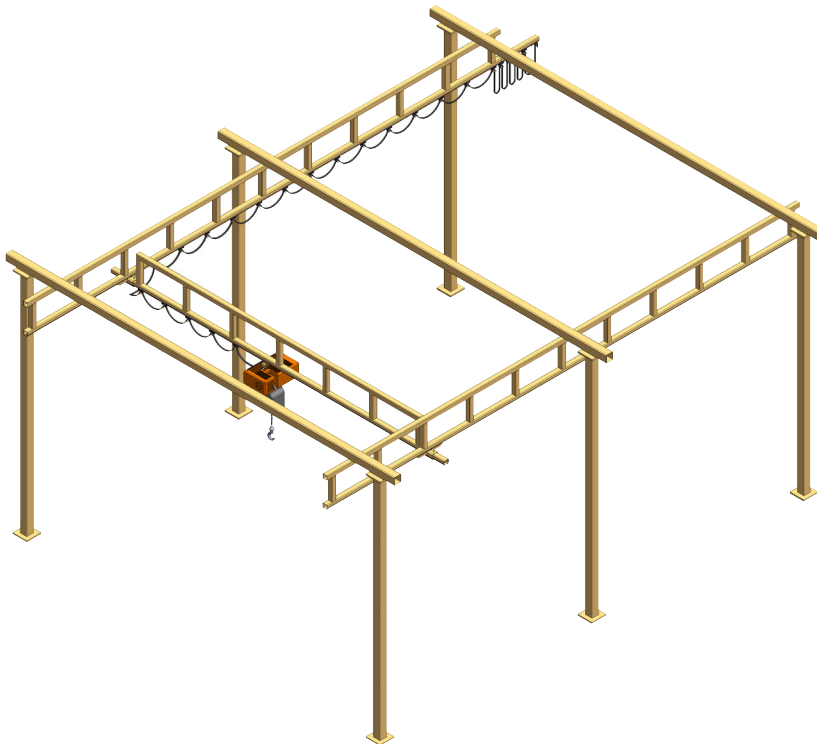

By using reinforced track profiles the runway support distance can be increased, removing the need for a parallel I-Beam to support the track. This method reduces the installation time.

(*) Sway bracing may be required for the ceiling support brackets that are not directly mounted (flush mounted) to the supporting structure in order to reduce the swinging effect. Sway bracing kits are not included in our standard product range but can be provided upon request.

Light crane systems

We reserve the right for technical amendments without obligation.
The product pictures and drawings depicted in this catalogue do not always reflect all available sizes.

Ceiling mounted crane with un-reinforced runway tracks

Ceiling mounted cranes are useful where the floor space is limited. Since the cranes are directly mounted on the ceiling and no supporting columns are necessary the working floors are kept clear for other operations. However it requires an adequate ceiling structure. Un-reinforced runways can be used when the distance between supports is small or by utilising I-beams or other structures at the ceiling.

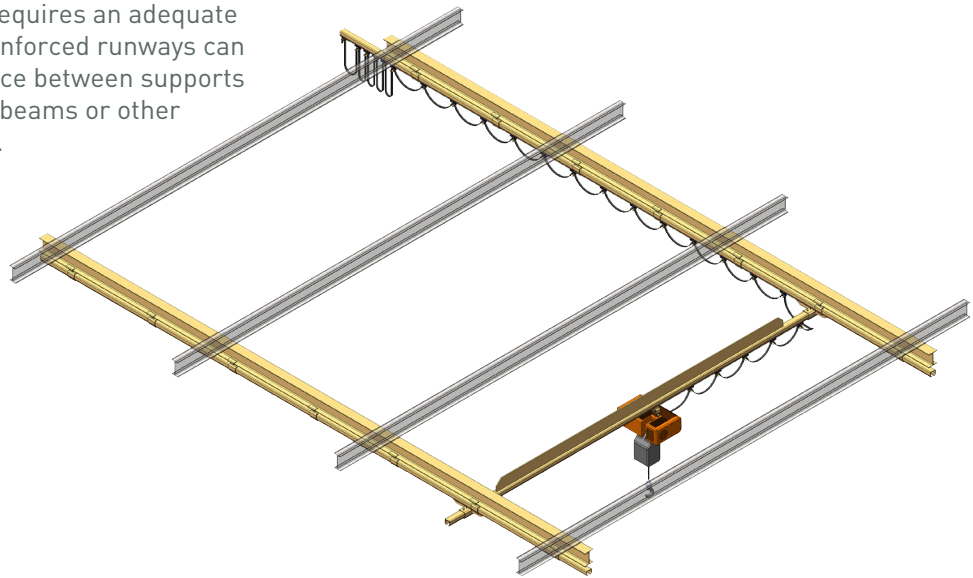

Ceiling mounted crane with reinforced runway track

The runway tracks can be reinforced to span longer distances between suspension points, when this is limited by the supporting structure.

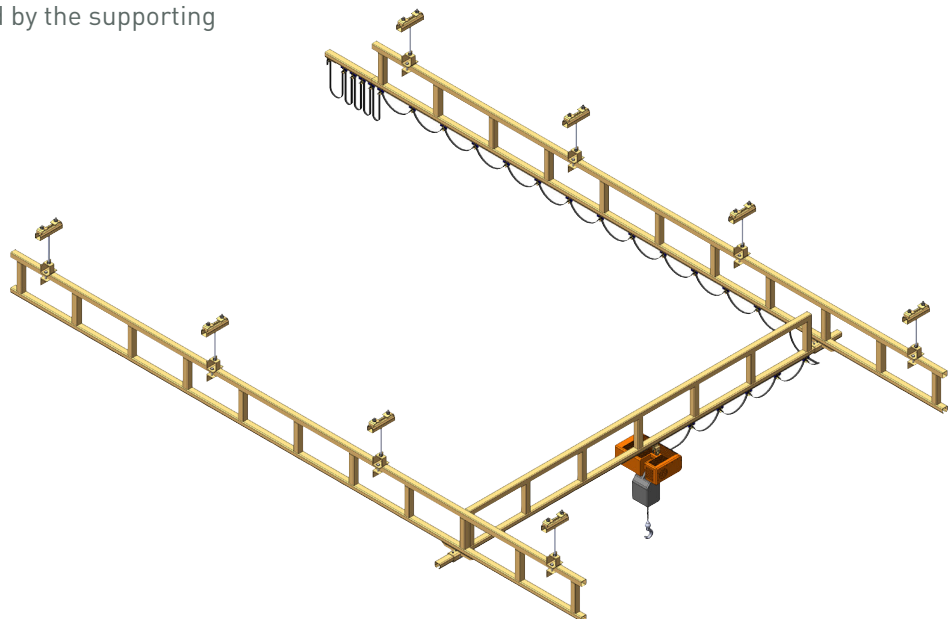

(*) Sway bracing may be required for the ceiling support brackets that are not directly mounted (flush mounted) to the supporting structure in order to reduce the swinging effect. Sway bracing kits are not included in our standard product range but can be provided upon request.

Light crane systems

We reserve the right for technical amendments without obligation.
The product pictures and drawings depicted in this catalogue do not always reflect all available sizes.

Version January 2018

www.niko.eu.com

Multiple bridge cranes

Multiple bridges can be used in the same long runway in order to accommodate multiple operators working at the same time. To prevent the crane bridges colliding buffer zones can be created using different methods. Creating buffer zones can enable multiple crane bridges to run within the same system without having to up-rate the runways. For example two 500kg crane bridges can run on 500kg runways, providing they are prevented from operating within the same support centres

Permanent buffer zones using end stops

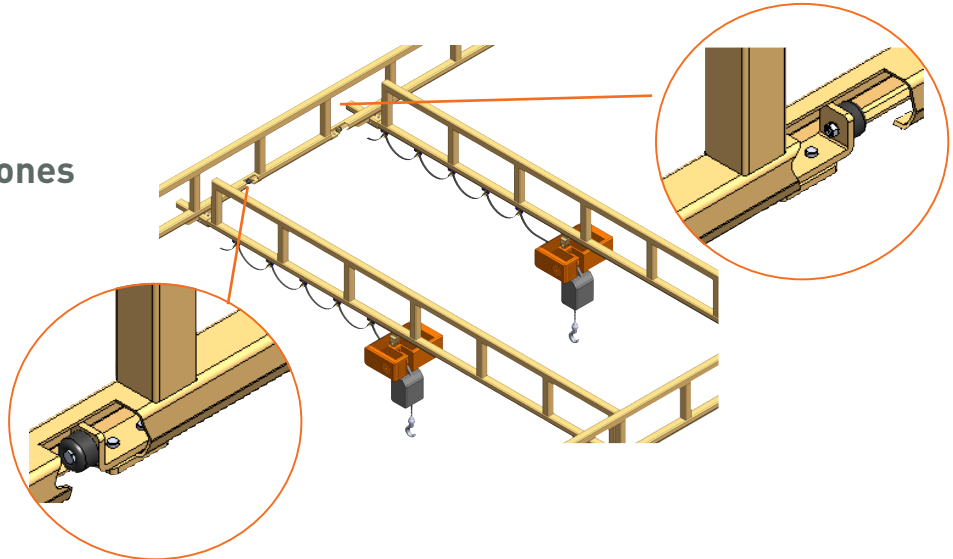

Buffer zones using fixed spacers

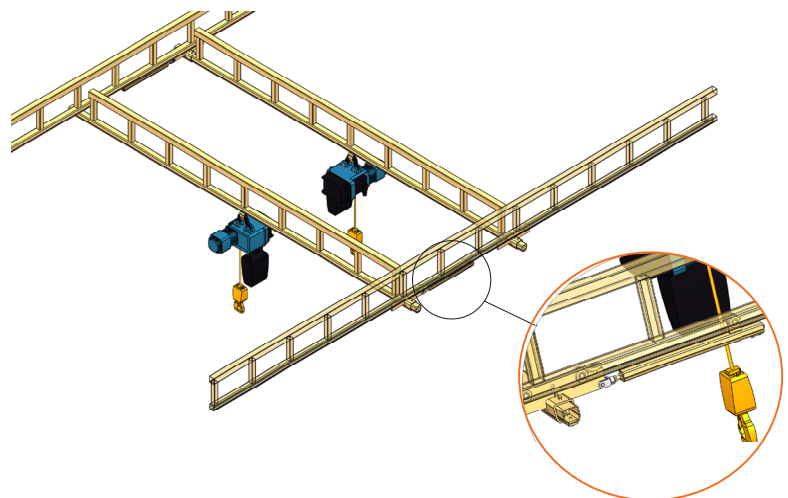

Buffer zone using mobile spacers

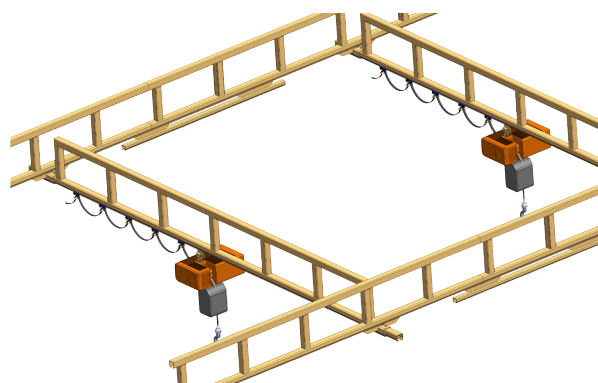

Stainless steel light crane series 304/316

NIKO stainless steel light cranes are necessary in industries where particulate contamination must be avoided. NIKO stainless steel series 304 is ideal for food and pharmaceutical industries, while NIKO stainless steel series 316 is indicated for offshore applications and chemical industry. Please find details regarding stainless steel components, at pages 58-62.

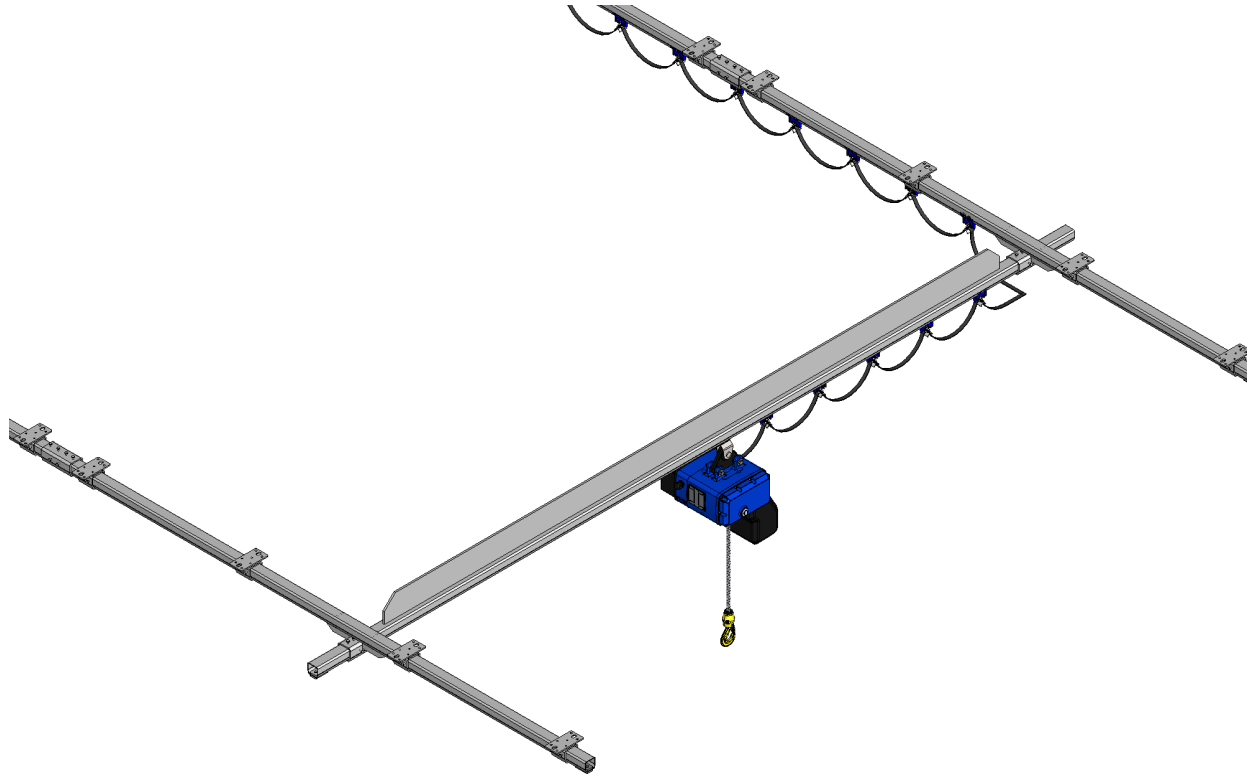

Capacity (Kg)	NIKO Profile No. Series 304	NIKO Profile No. Series 316	Bridge Length L max (m)	Long travel supporting distance B max (m)
80	23.050	23.070	1.50	1.00
	53.030	73.030	4.00	3.50
125	24.050	24.070	1.80	1.40
	54.030	74.030	5.00	4.40
	54.031	74.031	6.00	5.20
	54.080	74.080	7.00	6.40
	54.045	74.045	9.00	8.00
250	25.050	25.070	2.50	1.80
	55.030	75.030	6.00	5.20
	55.080	75.080	8.00	7.00
	55.045	75.045	10.00	9.00
500	Available upon request with reinforced tracks and carriages			

Festoon & conductor options

Power can be brought to the hoist or any other lifting device using festoons or conductor bars.

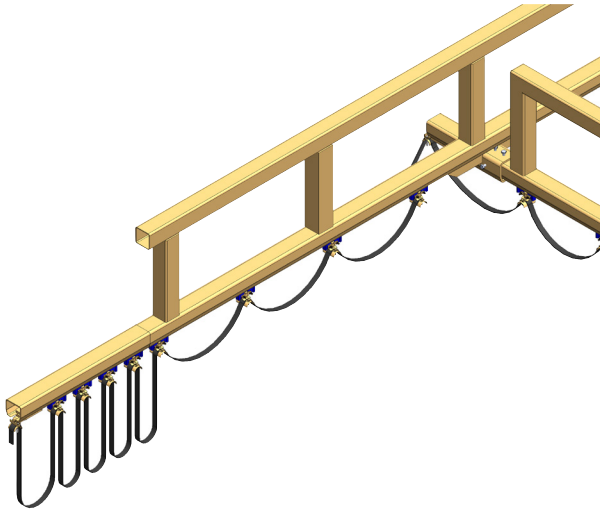

Internal festoon supply

Internal festoon cable supply creates a bunch-up at the feed end, which can restrict the travel across the bridge and runways. This can easily be rectified by extending the track tail to accommodate the bunch-up.

Parallel track festoon supply

NIKO track festoon systems are a possible solution for carrying power cables or hoses to cranes with a maximum of 2 bridges. For more detailed information on Festoon systems please refer to our Cable trolleys and festoon systems catalogue.

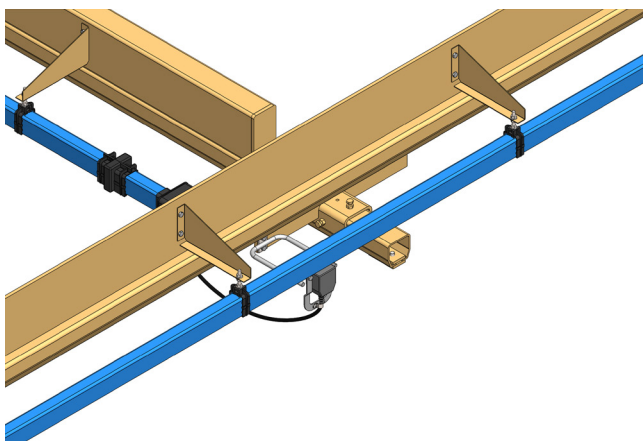
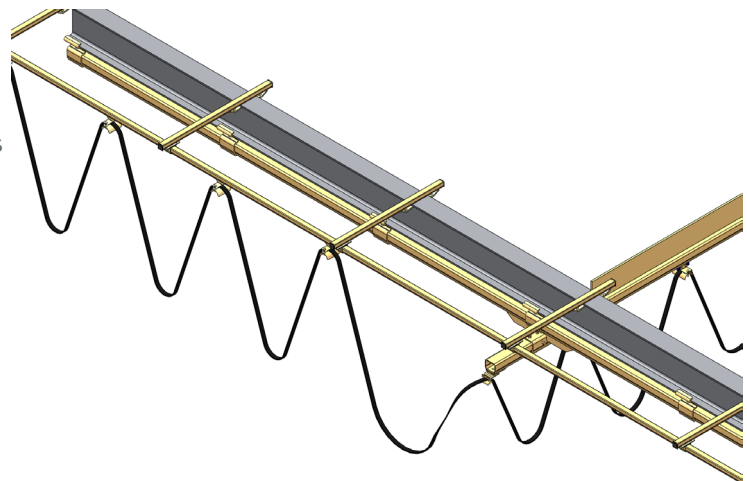

Typical conductor bar arrangement

Conductor bar supply systems do not have a bunch-up area at the feed end and therefore maximise the travel distance. Conductor bar also enables multiple bridges to receive power from a single feed point.

For detail information on our conductor bar product range, please refer to our Cable trolleys and festoon systems catalogue.

Light crane systems

We reserve the right for technical amendments without obligation. The product pictures and drawings depicted in this catalogue do not always reflect all available sizes.

Power driven trolleys

Light cranes & straight monorails can be motorised using our power driven trolleys (not suitable for travel round bends or through switches). These are generally only used for loads greater than 1000kg or if there are obstructions stopping the operator from pushing/pulling the the load. The power driven trolley operates using 4 high quality friction wheels that ensure long life and accuracy of movement. Electric travel is possible in 3 options: Electric travel only of the trolley running in the cross bridge (M1), electric travel only of the cross bridge itself (M2+M3) and complete electric travel in all movements (M1+M2+M3). Our power driven trolleys have inverter controlled motors that allow soft start and soft stop travel.

Typical applications

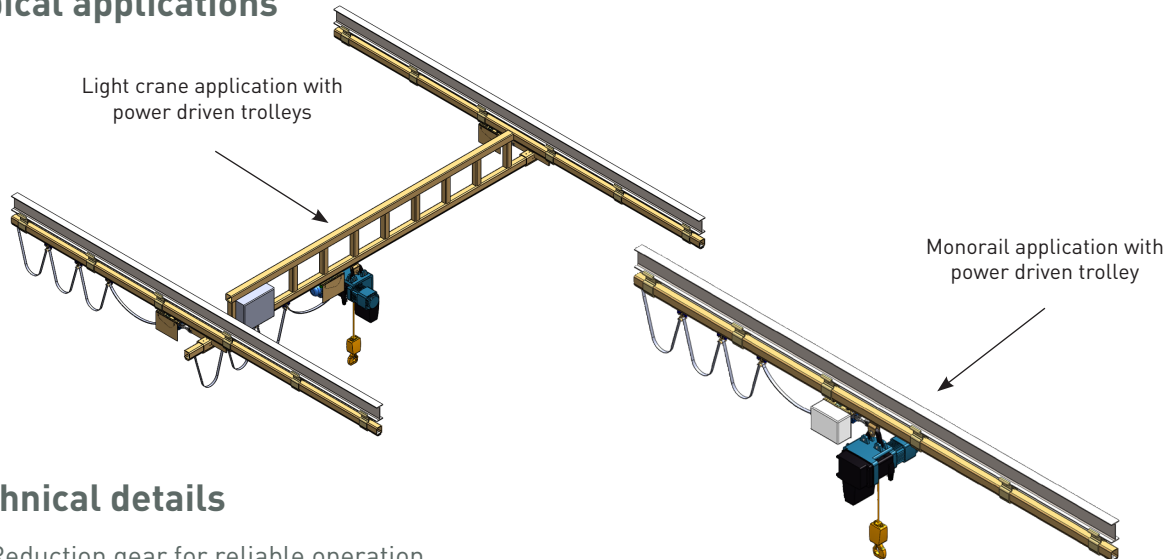

Technical details

- Reduction gear for reliable operation and low maintenance.
- Drive wheels molded with rubber for smooth acceleration.
- Standard motor units configured for 3 phase power 230-400 V.
- Power: 0,37 Kw , 1400 rpm motor, current: 230 V - 1,8 A / 400 V - 1,04 A.
- Inverter controlled speed , (lower speed 7m/min , higher speed 20m/min) with soft start & soft stop.

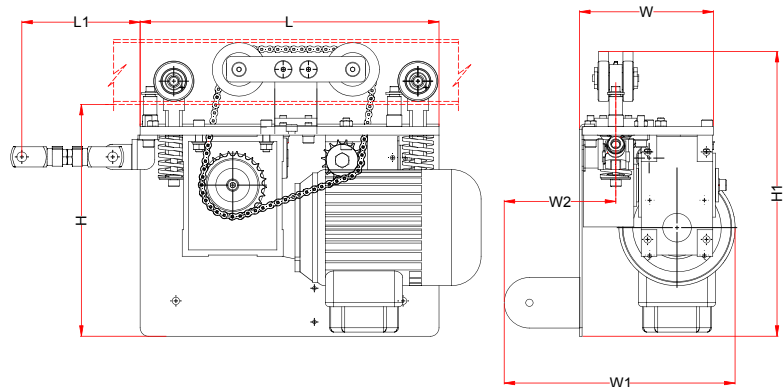

NIKO Profile No.	Power Driven Trolley	Transferred load (kg)	L (mm)	L1 (mm)	W (mm)	W1 (mm)	W2 (mm)	H (mm)	H1 (mm)
25.000	25.H120	500	355	145	160	260	142	275	332
26.000	26.H120	1000	355	145	160	260	142	276	347
27.000	27.H120	2000	355	180	160	260	142	277	380

Typical connection for power driven trolley .H120 to trolley .T48

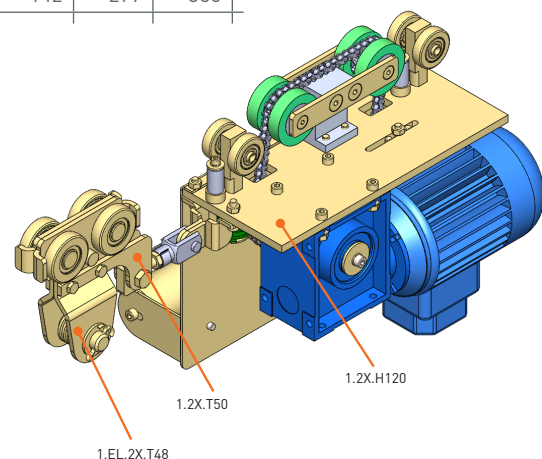

Light crane systems

We reserve the right for technical amendments without obligation. The product pictures and drawings depicted in this catalogue do not always reflect all available sizes.

Control panel & pendant control

Operation is controlled through an electrical control panel via a pendant or radio control unit.

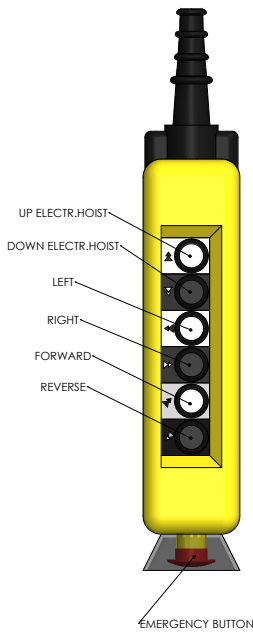

X3.702 PENDANT CONTROL WITH EMERGENCY BUTTON, 6 BUTTONS DUAL SPEED, OPERATION IS BEING CONTROLLED THROUGH A PENDANT CONTROL UNIT.

- For system with three power driven trolleys and inlet for connection of electrical hoist

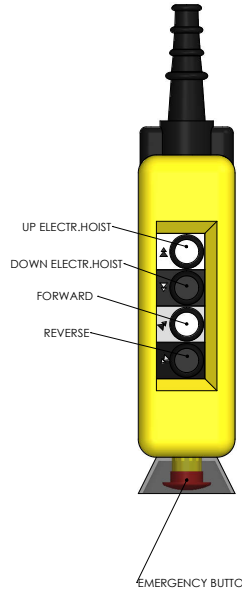

X3.701 PENDANT CONTROL WITH EMERGENCY BUTTON, 4 BUTTONS DUAL SPEED, OPERATION IS BEING CONTROLLED THROUGH A PENDANT CONTROL UNIT.

- For system with one or two power driven trolleys and inlet for connection of electrical hoist

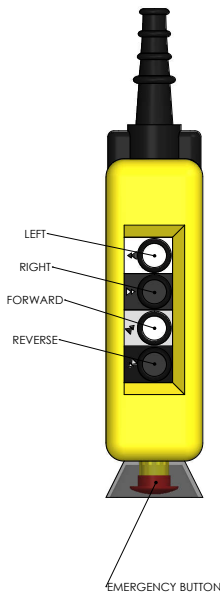

X3.701 PENDANT CONTROL WITH EMERGENCY BUTTON, 4 BUTTONS DUAL SPEED, OPERATION IS BEING CONTROLLED THROUGH A PENDANT CONTROL UNIT.

- For system with three power driven trolleys without connection for electrical hoist

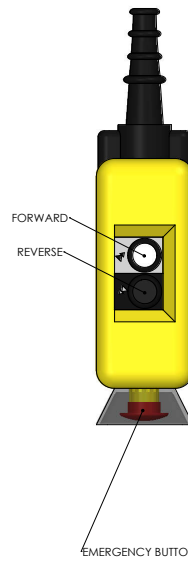

X3.700 PENDANT CONTROL WITH EMERGENCY BUTTON, 2 BUTTONS DUAL SPEED, OPERATION IS BEING CONTROLLED THROUGH A PENDANT CONTROL UNIT.

- For system with one or two power driven trolleys without connection for electrical hoist

Art No.	Description	Use
X3.114	Control Panel for power driven trolley Nr.25.000 - 27.000, with 2 inverter	For control of three power driven trolleys
X3.115	Control Panel for power driven trolley Nr.25.000 - 27.000, with 1 inverter	For control of two power driven trolleys
X3.116	Control Panel for power driven trolley Nr.25.000 - 27.000, with 1 inverter	For control of one power driven trolley
X3.700	Pendant control with emergency button (2 buttons, dual speed) & 4m long cable	For system with one power driven trolley
		For system with two power driven trolleys
X3.701	Pendant control with emergency button (4 buttons, dual speed) & 4m long cable	For system with one power driven trolley and inlet for connection of electr.hoist
		For system with two power driven trolleys and inlet for connection of electr.hoist
		For system with three power driven trolleys
X3.702	Pendant control with emergency button (6 buttons, dual speed) & 4m long cable	For system with three power driven trolleys and inlet for connection of electr.hoist

NIKO does not wire the control panel and power driven trolleys (supplied with plug-in connections and the pendant control with 4m cable). NIKO will only wire the power driven trolleys if specifically requested by the customer.

Radio remote control

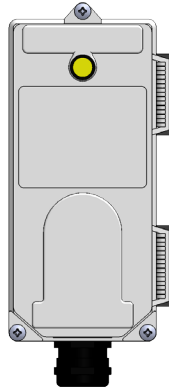
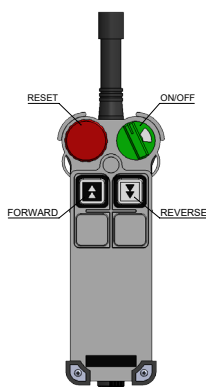

X3.726
RADIO REMOTE CONTROL
4D-2 POWER AC 48V-110V.
SET COMPLETE OF
N.1 DOUBLE SPEED 2 BUTTONS + START AND EMS STOP,
TRANSMITTER UNIT WITH COVER
N.1 WIRED RECEIVER
N.1 CHARGER WITH DOUBLE RECHARGEABLE BATTERIES

- For system with one or two power driven trolleys without connection for electrical hoist.

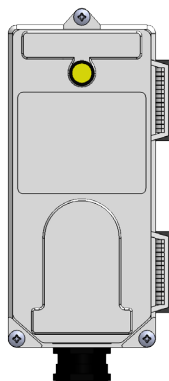
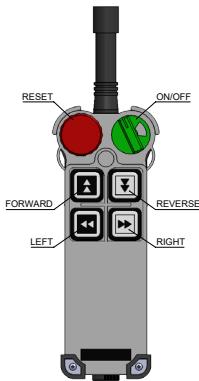

X3.727
RADIO REMOTE CONTROL
4D-2 POWER AC 48V-110V.
SET COMPLETE OF
N.1 DOUBLE SPEED 4 BUTTONS + START AND EMS STOP,
TRANSMITTER UNIT WITH COVER
N.1 WIRED RECEIVER
N.1 CHARGER WITH DOUBLE RECHARGEABLE BATTERIES

- For system with one or two power driven trolleys and inlet for connection of electrical hoist.

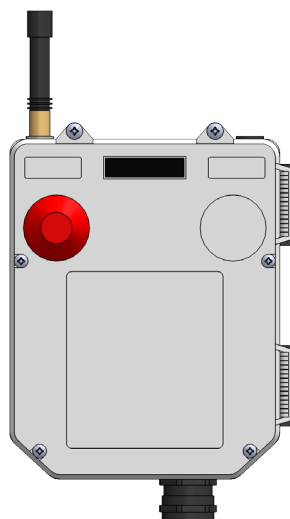
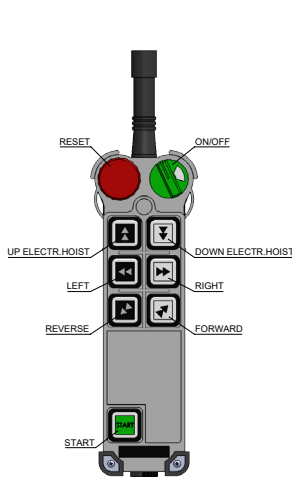

X3.728
RADIO REMOTE CONTROL
POWER 48V-110-220V.
SET COMPLETE OF
N.1 DOUBLE SPEED 6 BUTTONS + START AND EMS STOP,
TRANSMITTER UNIT WITH COVER
N.1 WIRED RECEIVER
N.1 CHARGER WITH DOUBLE
RECHARGEABLE BATTERIES

- For system with three power driven trolleys and inlet for connections of electrical hoist.

NIKO Electric chain hoists

- ✓ 3 phase electrical motor with electro magnetic brake , 380-400V, 50Hz.
- ✓ Double speed.
- ✓ Complete with 3m lifting height chain and cable, with chain container, (greater lifting height chain and cable available upon request , max lifting height for X3.610/620/630/640 22m for X3.650 11 m)
- ✓ Control pendant with emergency stop.
- ✓ Low voltage panel with high quality electric equipment.

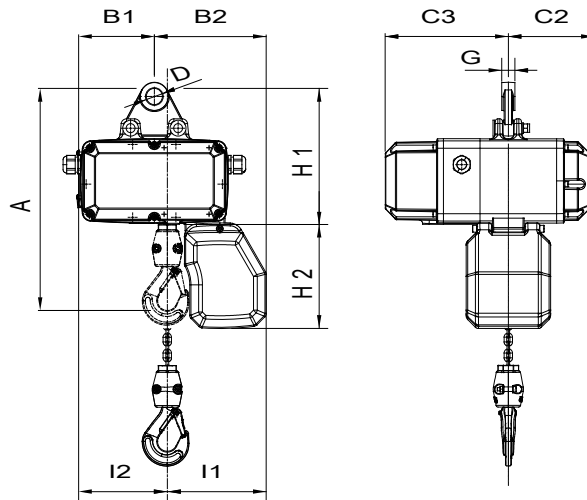
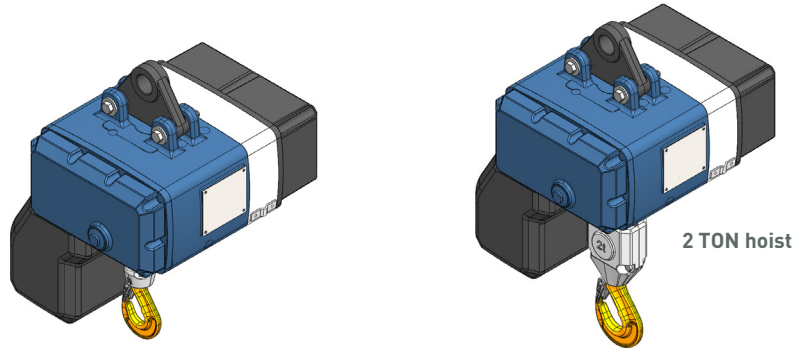

NIKO Profil No.	X3.610	X3.620	X3.630	X3.640	X3.650
Capacity kg.	125	250	500	1000	2000
Speed m/min.	8/2	8/2	8/2	8/2	4/1
Chain falls	1	1	1	1	2
Headroom A (mm)	420	420	420	454	541
B1 (mm)	148	148	148	174	174
B2 (mm)	212	212	212	260	260
C3 (mm)	235	235	235	266	266
C2 (mm)	169	169	169	186	186
D (mm)	24,5	24,5	24,5	36,5	36,5
G (mm)	25	25	25	30	30
I1 (mm)	187	187	187	235	271
I2 (mm)	172	172	172	194	162
H1 (mm)	250	250	250	285	285
H2 (mm)	275	275	275	328	328

PVC Flat cable

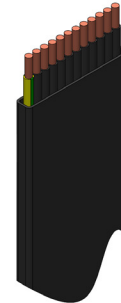
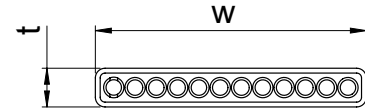

Part No.	Description	Cables (mm ²)	w (mm)	t (mm)	Approx Weight (g/m)	Permissible Current Rating [Amp.]	
1.X3.301	PVC Flat cable – 4core x 1.5mm ²	4x1,5	15	5	150	20	
1.X3.302	PVC Flat Cable 4core x 2.5mm ²	4x2,5	18,5	5,7	250	27	
1.X3.303	PVC Flat cable 8core x 1.5mm ²	8x1,5	29	5	295	14	
1.X3.304	PVC Flat cable 8core x 2.5mm ²	8x2,5	37	5,7	430	20	
1.X3.305	PVC Flat Cable 12core 1.5mm ²	12x1,5	41	5	415	11	
1.X3.306	PVC Flat cable 12core x 2.5mm ²	12x2,5	51	5,7	630	16	
1.X3.307	PVC flat cable 4core x 4mm ²	4x4	21,5	6,9	320	36	
1.X3.308	PVC Flat cable 4core x 6mm ²	4x6	24,5	7,6	430	48	
1.X3.309	PVC Flat cable 4core x 10mm ²	4x10	31	9,6	690	63	
1.X3.310	PVC Flat cable 4core x 16mm ²	4x16	35,5	10,9	970	85	
1.X3.311	PVC flat cable 12core x 32mm ²	12x32	available upon request				
1.X3.312	PVC flat cable 5core x 4mm ²	5x4	26	6,9x26	390	36	
1.X3.313	PVC flat cable 7core 4mm ²	7x4	38	6,9x38	560	25	

LIGHT CRANE SYSTEMS

Pendant cable

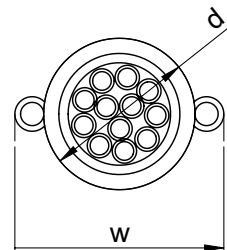

Part No.	Description	Cables (mm ²)	w (mm)	d (mm)	Approx Weight (g/m)	Permissible Current Rating [Amp.]
1.X3.314	NikoFLEX pendant cable 5core x 1.5mm ²	5x1,5	21,5	10,5	240	20
1.X3.315	NikoFLEX Pendant cable 8core x 1.5mm ²	8x1,5	23,6	13,4	420	20
1.X3.316	NikoFlex Pendant cable 12core x 1.5mm ²	12x1,5	25,7	16,5	515	20
1.X3.317	NikoFlex Pendant cable 16core x 1.5mm ²	16x1,5	27,4	18,2	600	20
1.X3.318	NikoFlex Pendant cable 20core x 1.5mm ²	20x1,5	28,2	19	800	20
1.X3.319	NikoFlex Pendant cable 24core x 1.5mm ²	24x1,5	31,1	21,9	960	20
1.X3.320	BOITALYON Pendant Cable 30core x 1.5mm ²	30x1,5	32,9	23,7	1120	20
1.X3.321	Pendant Cable with central Strainer Wire 5core x 1mm ²	5x1		10,4	171	15

Light crane systems

We reserve the right for technical amendments without obligation.
The product pictures and drawings depicted in this catalogue do not always reflect all available sizes.

Version January 2018

www.niko.eu.com

17

Telescopic monorail and cranes

In order to cover a wider area than the supporting space structure permits, a telescopic cross bridge is available. Using our components telescopic cranes are also possible which are very often installed in containers and trucks and used in the automotive industry for tool suspension.

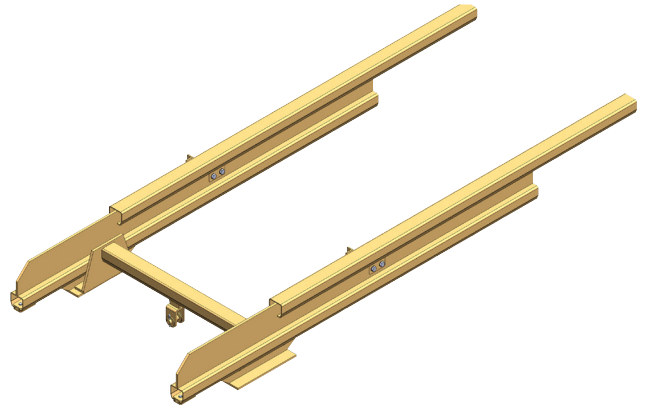
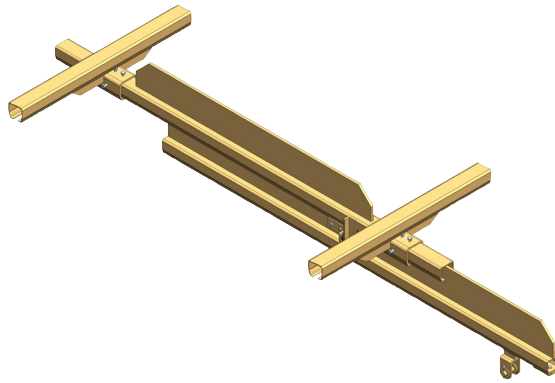
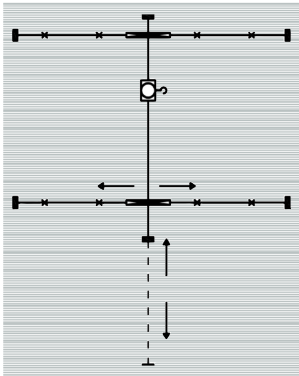

LIGHT CRANE SYSTEMS

NIKO Profil No.	23.000	24.000	25.000	26.000	27.000
P max Kg	40	75	125	250	500
A max mm	1200	1200	1300	1300	1300

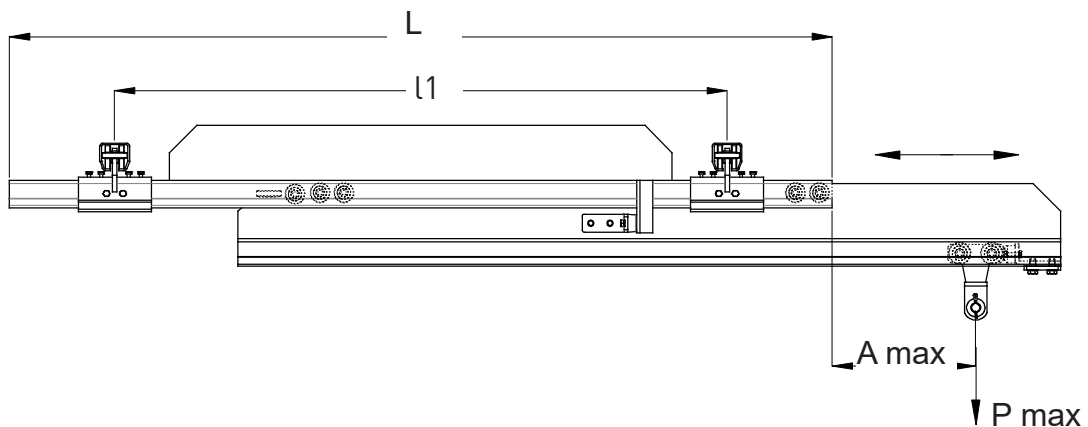

Light crane systems

We reserve the right for technical amendments without obligation.
The product pictures and drawings depicted in this catalogue do not always reflect all available sizes.

Version January 2018

www.niko.eu.com

Interlocks

Interlocks are used to connect a crane with another crane or an extended conveyor system. The load carrying trolley is transferred safely from one system to the other.

Interlock with built-in safety device (.H21/.H22)

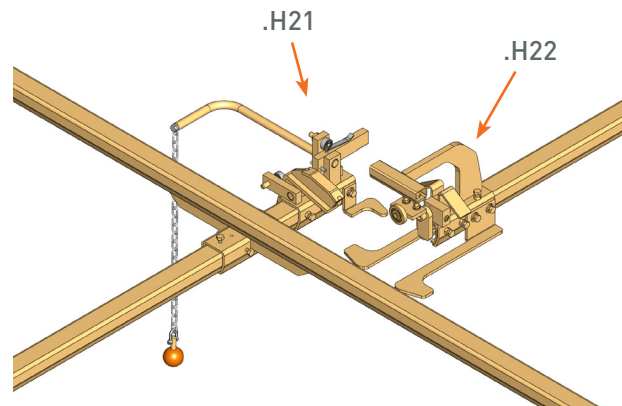

Interlock with externally safety plate (.H01/.H02)

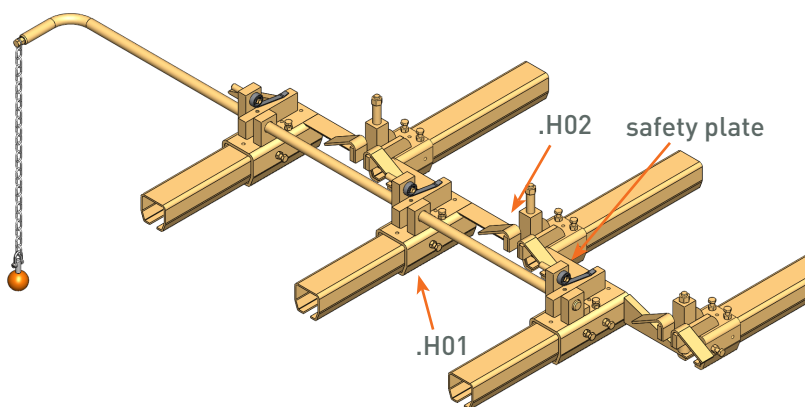

LIGHT CRANE SYSTEMS

Manipulator

NIKO light cranes are often used to suspend different types of manipulators form. Our engineering department is capable of providing bespoke solutions to our customers needs.

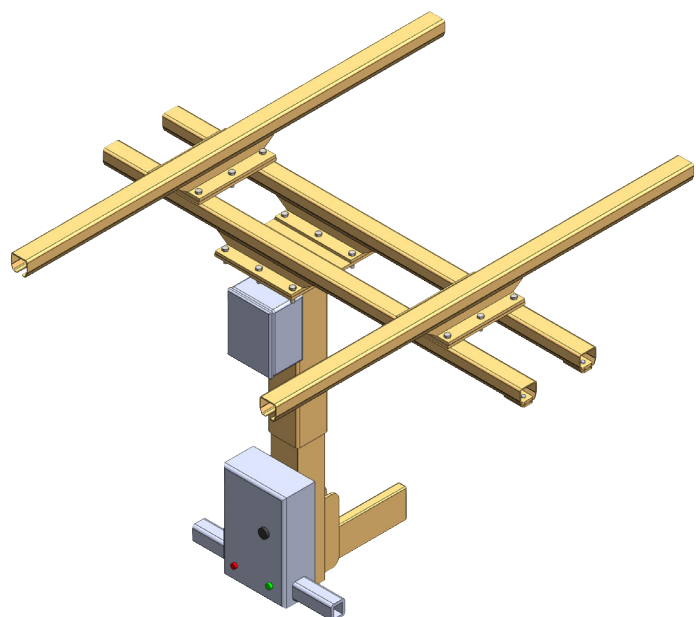

Light crane systems

We reserve the right for technical amendments without obligation. The product pictures and drawings depicted in this catalogue do not always reflect all available sizes.

Conveyor systems

NIKO conveyor systems can be used in a variety of applications utilising more than 2.000 components such as switches and turn tables. Please refer to our brochure C1 for more information.

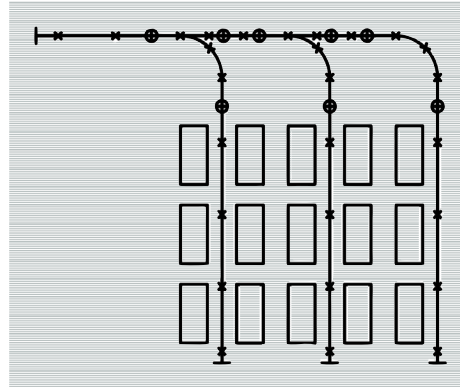
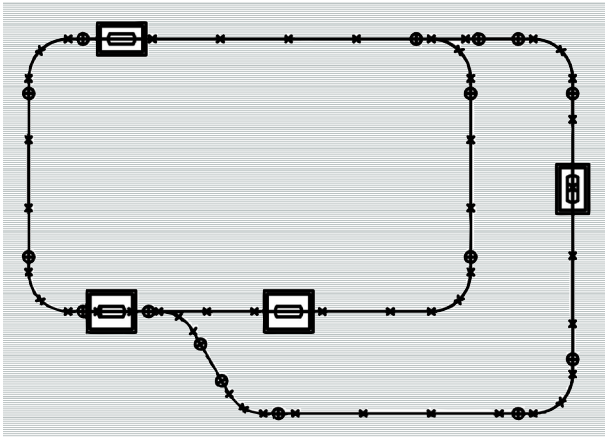
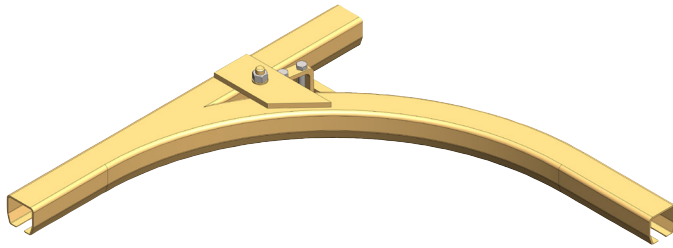

LIGHT CRANE SYSTEMS

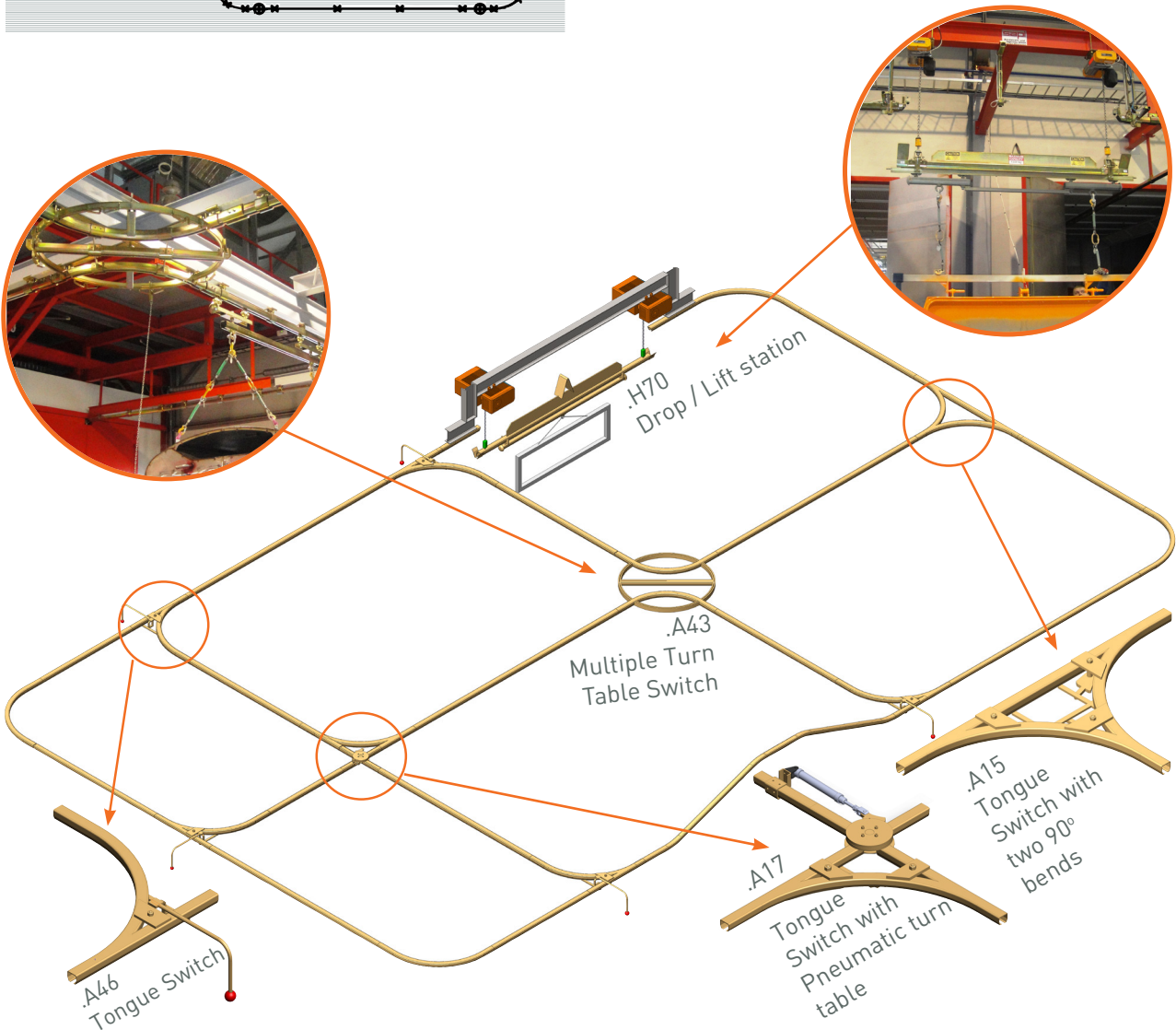

Jib cranes

Over-braced (OB) Profile Jib cranes

OB Profile Jib cranes are braced above the NIKO track profile. This type of jib provides the most free running travel along the arm and therefore is generally the easiest type for the operator to use. (Stainless steel jib cranes are available upon request).

Freestanding Jib crane

NIKO freestanding jib cranes are supplied in kit form and comprise of 2 main parts: the pillar and the arm. The pillars are designed and fabricated to suspend the required jib arm type. The arm is fixed to the column using a pivot pin. The arm then rotates around the pillar and enables lifting within a predetermined arc.

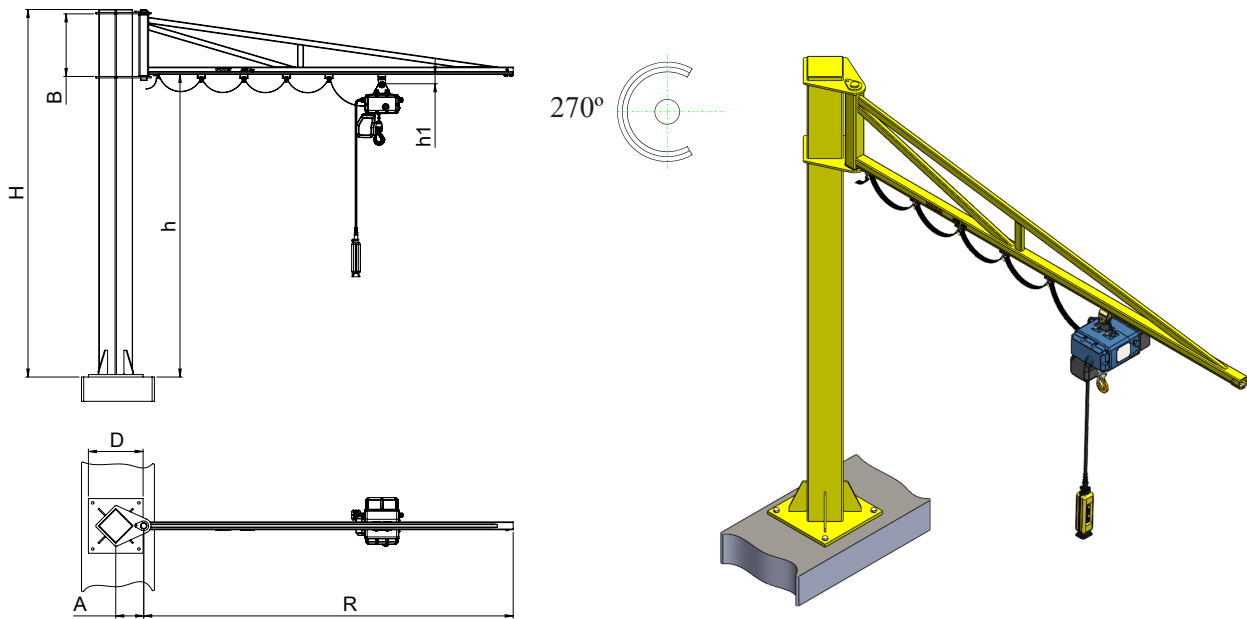

SWL (kg)	Free standing OB Profile Jib Crane NIKO Part No.	Arm Dimensions				Freestanding pillar Dimensions			
		Radius R (m)	NIKO track Profile	Kingpin Height B (mm)	Trolley Depth h1 (mm)	Overall Height H (mm)	Height to Under Arm h (mm) *	Pivot Point A (mm)	Base Size D (mm)
80	24.J053.K30	3	24.000	500	65	3000	2500	230	450x450
	24.J054.K30	4	24.000	500	65	3000	2500	230	450x450
	24.J065.K30	5	24.000	600	65	3000	2400	230	450x450
	25.J066.K30	6	25.000	600	77	3000	2400	260	600x600
125	25.J053.K30	3	25.000	500	77	3000	2500	230	450x450
	25.J054.K30	4	25.000	500	77	3000	2500	230	450x450
	25.J065.K30	5	25.000	600	77	3000	2400	230	600x600
	25.J0756.K30	6	25.000	750	77	3000	2250	260	600x600
250	25.J063.K30	3	25.000	600	77	3000	2400	230	450x450
	25.J064.K30	4	25.000	600	77	3000	2400	260	600x600
	26.J0755.K30	5	26.000	750	94	3000	2250	260	600x600
	26.J0856.K30	6	26.000	850	94	3000	2150	260	700x700
500	26.J0753.K35	3	26.000	750	94	3500	2750	260	600x600
	26.J0754.K35	4	26.000	750	94	3500	2750	260	600x600
	27.J0855.K35	5	27.000	850	123	3500	2650	260	600x600
	27.J106.K35	6	27.000	1000	123	3500	2500	315	700x700
1000	27.J0753.K35	3	27.000	750	123	3500	2750	315	700x700
	27.J0854.K35	4	27.000	850	123	3500	2650	315	700x700

* Columns are available up to 5 metres upon request.

Light crane systems

We reserve the right for technical amendments without obligation. The product pictures and drawings depicted in this catalogue do not always reflect all available sizes.

Version January 2018

www.niko.eu.com

Clamp around Column Mounted Jib Cranes

NIKO column mounted jib cranes comprise of an arm and a pair of brackets that can be clamped around an existing building column/stanchion/pillar. The support structure must be tested by a structural engineer to ensure it is strong enough to sustain the weight of the jib when loaded. The arm is then located between the pair of clamping brackets and fixed using a pivot pin. The arm then rotates around the support column and enables lifting within a predetermined arc. Anti-slip measures must be taken to ensure that the jib crane cannot slip down the support column.

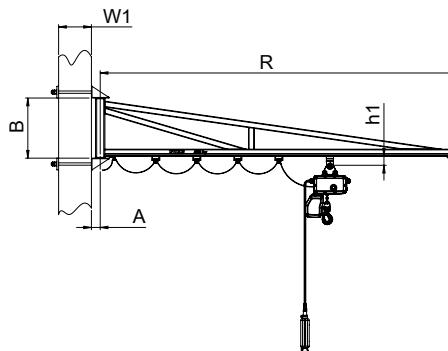
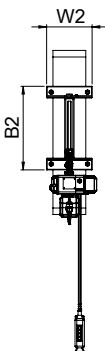
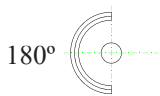
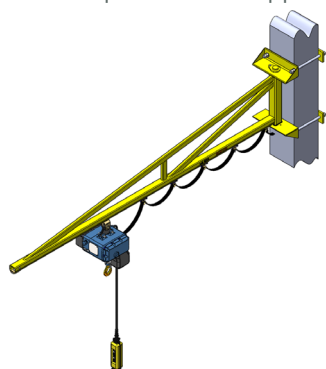

Wall Mounted Jib crane

NIKO wall mounted jib cranes comprise of an arm and a pair of brackets that can be bolted or welded to an existing wall or building column/stanchion/pillar. The support structure must be tested by a structural engineer to ensure it is strong enough to sustain the weight of the jib when loaded. The arm is then located between the pair of clamping brackets and fixed using a pivot pin. The arm then rotates around the support column and enables lifting within a predetermined arc.

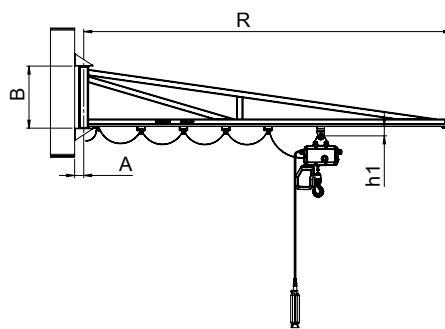
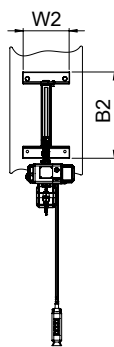
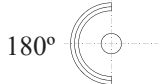
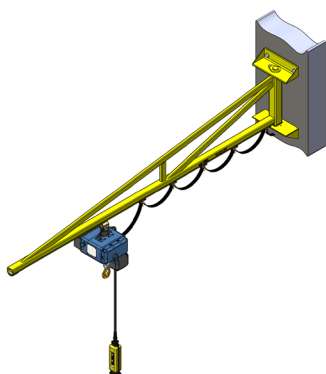

SWL (kg)	NIKO Profile Jib Crane Part No.		Arm Dimensions				Wall/Face Mounted & Clamp Around Column Bracket Dimensions			
	Column Mounted	Wall Mounted	R (m)	NIKO Track Profile	Kingpin Height B (mm)	Trolley Depth h1 (mm)	Overall Height B2 (mm)	Bracket Width W2 (mm)	W1 (mm)	Pivot Point A (mm)
80	24.J053.C	24.J053	3	24.000	500	65	680	380	500	75
	24.J054.C	24.J054	4	24.000	500	65	680	380	500	75
	24.J065.C	24.J065	5	24.000	600	65	780	380	500	75
	25.J066.C	25.J066	6	25.000	600	77	780	380	500	75
125	25.J053.C	25.J053	3	25.000	500	77	680	380	500	75
	25.J054.C	25.J054	4	25.000	500	77	680	380	500	75
	25.J065.C	25.J065	5	25.000	600	77	780	380	500	75
	25.J0756.C	25.J0756	6	25.000	750	77	930	380	500	75
250	25.J063.C	25.J063	3	25.000	600	77	780	380	500	75
	25.J064.C	25.J064	4	25.000	600	77	780	380	500	75
	26.J0755.C	26.J0755	5	26.000	750	94	930	380	500	75
	26.J0856.C	26.J0856	6	26.000	850	94	1030	380	500	75
500	26.J0753.C	26.J0753	3	26.000	750	94	930	380	500	75
	26.J0754.C	26.J0754	4	26.000	750	94	930	380	500	75
	27.J0855.C	27.J0855	5	27.000	850	123	1050	380	500	105
	27.J106.C	27.J106	6	27.000	1000	123	1200	380	500	105
1000	27.J0753.C	27.J0753	3	27.000	750	123	950	380	500	105
	27.J0854.C	27.J0854	4	27.000	850	123	1050	380	500	105

Under-braced (UB) I-beam Jib cranes

I-Beam Jib Cranes are generally used when powered travel is required along the arm. Under-braced I-beam jib cranes, are braced below the arm onto the underside of an I-beam. These are the lowest headroom variation and therefore are normally used in areas where headroom is limited.

(Stainless steel jib cranes are available upon request).

Freestanding Jib crane

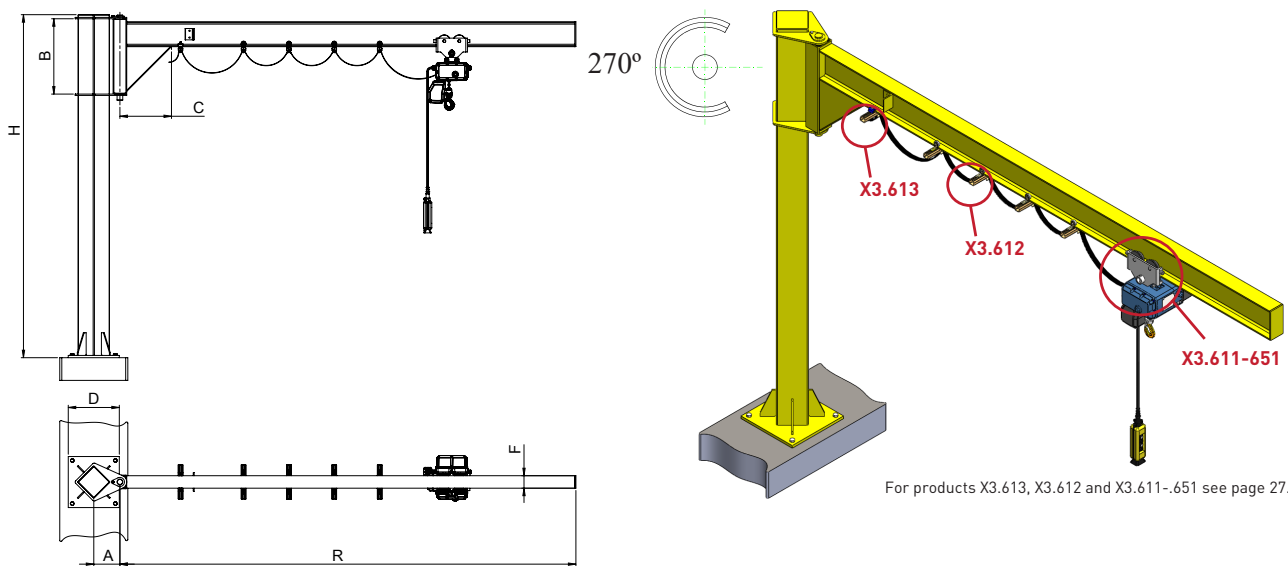

For products X3.613, X3.612 and X3.611-651 see page 27.

LIGHT CRANE SYSTEMS

SWL (kg)	Free standing OB Profile Jib Crane NIKO Part No.	Arm Dimensions				Freestanding Pillar Dimensions		
		Radius R (m)	Flange width F (mm)	Kingpin Height B (mm)	Under bracing length C (mm)	Overall Height H (mm) *	Pivot Point A (mm)	Base Size D (mm)
80	180.U053.K30.0080	3	91	500	320	3000	230	450x450
	180.U054.K30.0080	4	91	500	320	3000	230	450x450
	200.U065.K30.0080	5	100	600	400	3000	230	450x450
	200.U066.K30.0080	6	100	600	400	3000	260	600x600
125	180.U053.K30.0125	3	91	500	320	3000	230	450x450
	200.U054.K30.0125	4	100	500	400	3000	230	450x450
	200.U065.K30.0125	5	100	600	500	3000	260	600x600
	240.U0756.K30.0125	6	120	750	500	3000	260	600x600
250	200.U063.K30.0250	3	100	600	400	3000	230	600x600
	240.U064.K30.0250	4	120	600	400	3000	260	600x600
	240.U0755.K30.0250	5	120	750	500	3000	260	700x700
	270.U0856.K30.0250	6	135	850	550	3000	260	700x700
500	240.U0753.K30.0500	3	120	750	500	3000	260	450x450
	270.U0754.K30.0500	4	135	750	500	3000	260	600x600
	360.U0855.K30.0500	5	170	850	500	3000	315	600x600
	400.U106.K30.0500	6	180	1000	600	3000	315	700x700
1000	270.U0753.K30.1000	3	135	750	450	3000	315	700x700
	360.U0854.K30.1000	4	170	850	500	3000	315	700x700

Light crane systems

We reserve the right for technical amendments without obligation.
The product pictures and drawings depicted in this catalogue do not always reflect all available sizes.

B. Clamp around Column Mounted Jib Cranes

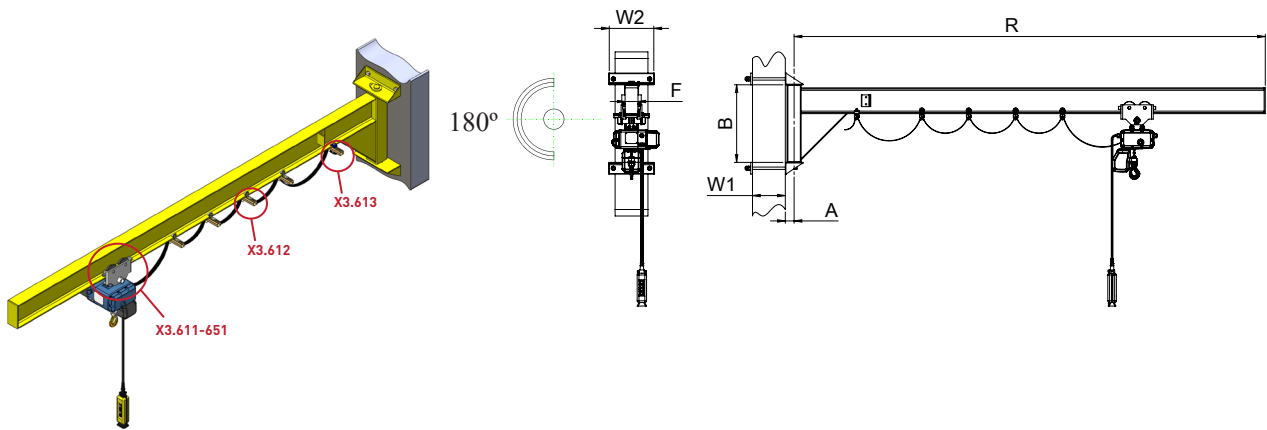

C. Wall Mounted Jib crane

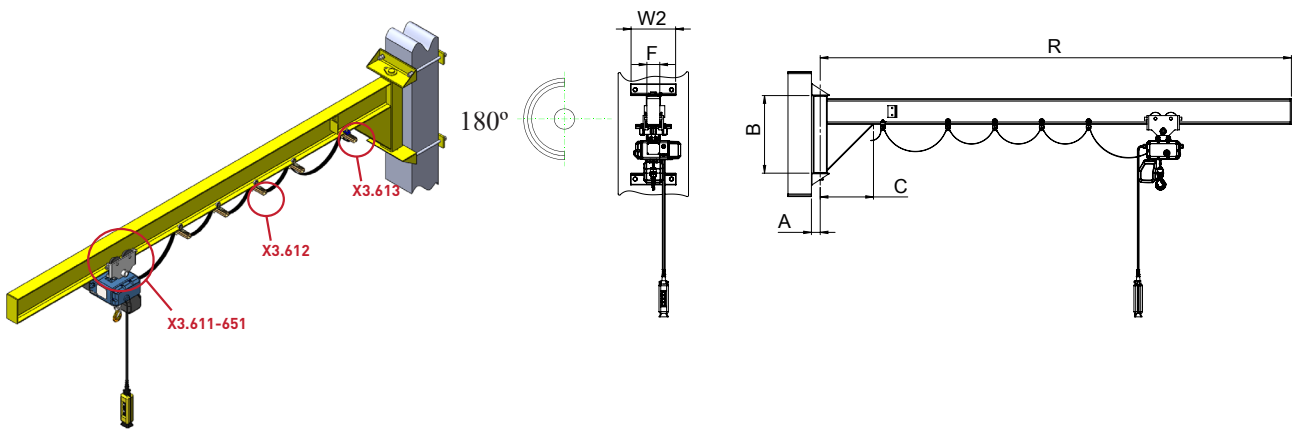

For products X3.613, X3.612 and X3.611-651 see page 27.

SWL (kg)	I-Beam Jib crane Part No.		Arm Dimensions				Wall/Face mounted & clamp around column bracket dimensions		
	Column mounted	Wall mounted	R (m)	Flange width F (mm)	Kingpin Height B (mm)	Under bracing length C (mm)	Bracket Width W2 (mm)	W1 (mm)	Pivot Point A (mm)
80	180.U053.C.0080	180.U053.0080	3	91	500	320	380	500	75
	180.U054.C.0080	180.U054.0080	4	91	500	320	380	500	75
	200.U065.C.0080	200.U065.0080	5	100	600	400	380	500	75
	200.U066.C.0080	200.U066.0080	6	100	600	400	380	500	105
125	180.U053.C.0125	180.U053.0125	3	91	500	320	380	500	75
	200.U054.C.0125	200.U054.0125	4	100	500	400	380	500	105
	200.U065.C.0125	200.U065.0125	5	100	600	500	380	500	105
	240.U0756.C.0125	240.U0756.0125	6	120	750	500	380	500	105
250	200.U063.C.0250	200.U063.0250	3	100	600	400	380	500	75
	240.U064.C.0250	240.U064.0250	4	120	600	400	380	500	105
	240.U0755.C.0250	240.U0755.0250	5	120	750	500	380	500	105
	270.U0856.C.0250	270.U0856.0250	6	135	850	550	380	500	105
500	240.U0753.C.0500	240.U0753.0500	3	120	750	500	380	500	105
	270.U0754.C.0500	270.U0754.0500	4	135	750	500	380	500	105
	360.U0855.C.0500	360.U0855.0500	5	170	850	500	380	500	105
	400.U106.C.0500	400.U106.0500	6	180	1000	600	380	500	105
1000	270.U0753.C.1000	270.U0753.1000	3	135	750	450	380	500	105
	360.U0854.C.1000	360.U0854.1000	4	170	850	500	380	500	105

Over-braced (OB) I-beam Jib cranes

Over-braced I-beam jib cranes are braced the same as profile arms, but with an I-beam underneath rather than a NIKO track profile. These are generally used when powered travel is required along the arm. (Stainless steel jib cranes are available upon request).

A. Freestanding Jib crane

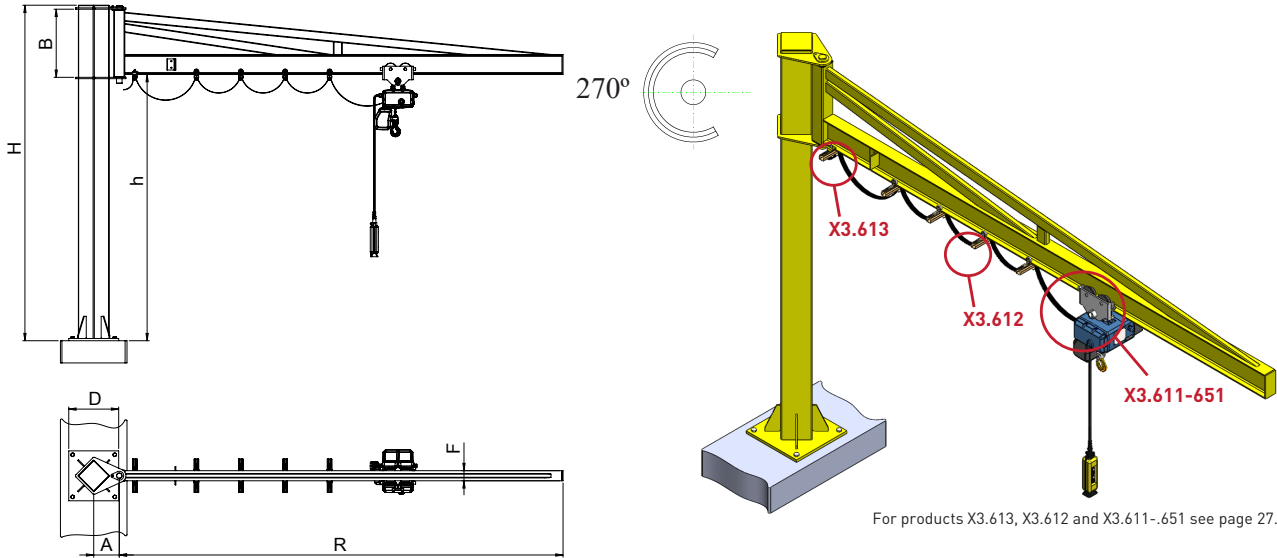

SWL (kg)	Free stading OB I-beam Jib Crane NIKO Part No.	Arm Dimensions			Freestanding pillar Dimensions			
		Radius R (m)	Flange width F (mm)	Kingpin Height B (mm)	Overall Height H (mm) *	Height to Under Arm h (mm)	Pivot Point A (mm)	Base Size D (mm)
80	180.0053.K30.0080	3	91	500	3000	2500	230	450x450
	180.0054.K30.0080	4	91	500	3000	2500	230	450x450
	180.0065.K30.0080	5	91	600	3000	2400	230	450x450
	180.0066.K30.0080	6	91	600	3000	2400	230	600x600
125	180.0053.K30.0125	3	91	500	3000	2500	230	450x450
	180.0054.K30.0125	4	91	500	3000	2500	230	450x450
	180.0065.K30.0125	5	91	600	3000	2400	230	600x600
	180.00756.K30.0125	6	91	750	3000	2250	260	600x600
250	180.0063.K30.0250	3	91	600	3000	2400	230	450x450
	180.0064.K30.0250	4	91	600	3000	2400	260	600x600
	180.00755.K30.0250	5	91	750	3000	2250	260	600x600
	180.00856.K30.0250	6	91	850	3000	2150	260	700x700
500	180.00753.K35.0500	3	91	750	3500	2750	260	600x600
	180.00754.K35.0500	4	91	750	3500	2750	315	700x700
	180.00855.K35.0500	5	91	850	3500	2650	315	700x700
	200.0106.K35.0500	6	100	1000	3500	2500	315	700x700
1000	180.00753.K35.1000	3	91	750	3500	2750	315	700x700
	200.00854.K35.1000	4	100	850	3500	2650	315	700x700

* Columns are available up to 5 metres upon request.

Light crane systems

We reserve the right for technical amendments without obligation. The product pictures and drawings depicted in this catalogue do not always reflect all available sizes.

B. Clamp around Column Mounted Jib Cranes

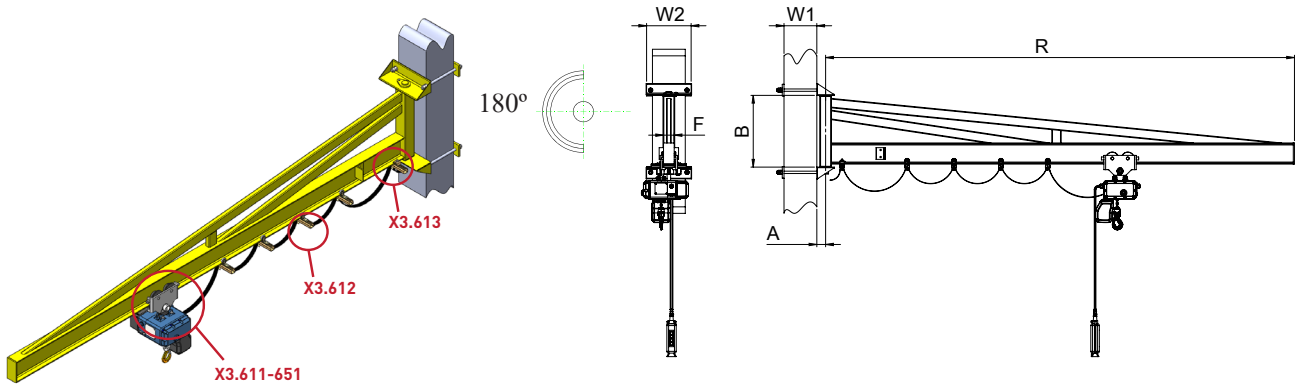

C. Wall Mounted track Jib crane

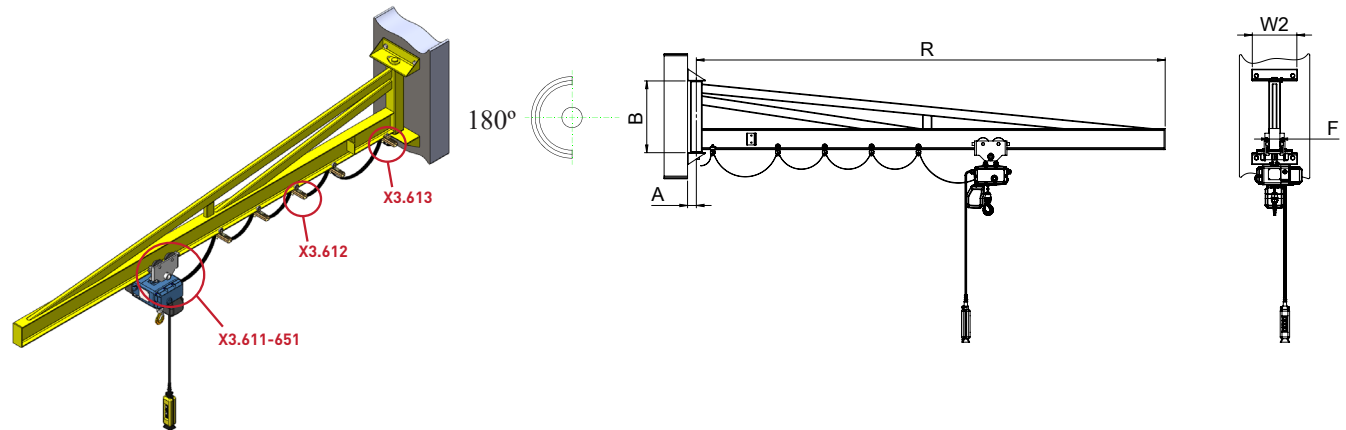

For products X3.613, X3.612 and X3.611-.651 see page 27.

SWL (kg)	I-Beam Jib crane Part No.		Arm Dimensions			Wall/Face Mounted & Clamp Around Column Bracket Dimensions			
	Column mounted	Wall mounted	R (m)	Flange width F (mm)	Kingpin Height B (mm)	Overall Height B2 (mm)	Bracket Width W2 (mm)	W1 (mm)	Pivot Point A (mm)
80	180.0053.C.0080	180.0053.0080	3	91	500	680	380	500	75
	180.0054.C.0080	180.0054.0080	4	91	500	680	380	500	75
	180.0065.C.0080	180.0065.0080	5	91	600	780	380	500	75
	180.0066.C.0080	180.0066.0080	6	91	600	780	380	500	75
125	180.0053.C.0125	180.0053.0125	3	91	500	680	380	500	75
	180.0054.C.0125	180.0054.0125	4	91	500	680	380	500	75
	180.0065.C.0125	180.0065.0125	5	91	600	780	380	500	75
	180.00756.C.0125	180.00756.0125	6	91	750	930	380	500	75
250	180.0063.C.0250	180.0063.0250	3	91	600	780	380	500	75
	180.0064.C.0250	180.0064.0250	4	91	600	780	380	500	75
	180.00755.C.0250	180.00755.0250	5	91	750	930	380	500	75
	180.00856.C.0250	180.00856.0250	6	91	850	1030	380	500	75
500	180.00753.C.0500	180.00753.0500	3	91	750	930	380	500	75
	180.00754.C.0500	180.00754.0500	4	91	750	930	380	500	75
	180.00855.C.0500	180.00855.0500	5	91	850	1050	380	500	105
	200.0106.C.0500	200.0106.0500	6	100	1000	1200	380	500	105
1000	180.00753.C.1000	180.00753.1000	3	91	750	950	380	500	105
	200.00854.C.1000	200.00854.1000	4	100	850	1050	380	500	105

Trolley for hoist for direct movement on I profile

X3.611/.651

NIKO Profile No.	X3.611	X3.621	X3.631	X3.641	X3.651
W min. (mm)	62	62	62	80	106
W max. (mm)	152	152	152	203	203
l (mm)	240	240	240	286	316
L (mm)	100	100	100	120	132
H1 (mm)	67	67	67	87	94
H2 (mm)	183	183	183	203	210

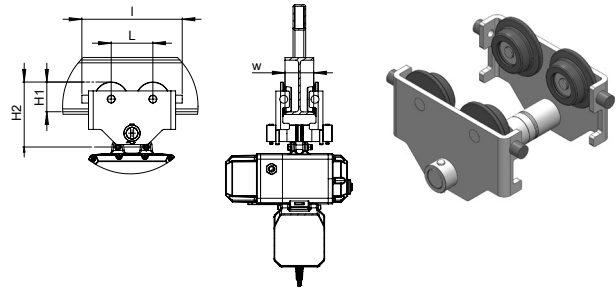

Cable trolley for direct movement on I profile

X3.612

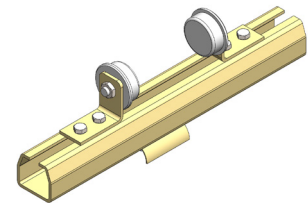
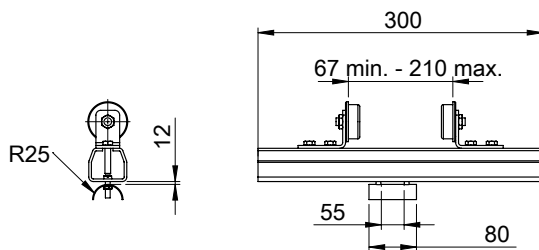

Cable end clamp for I profile

X3.613

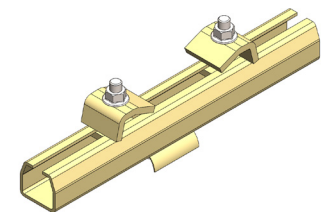
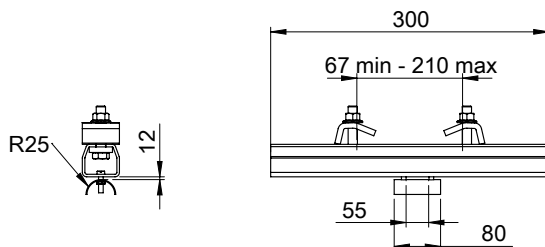

Slewing limit for jib cranes

.L

The slewing limit restricts the rotation of the arm for such angles as to prevent the impact of the load at fixed points and contribute in safer work-space.

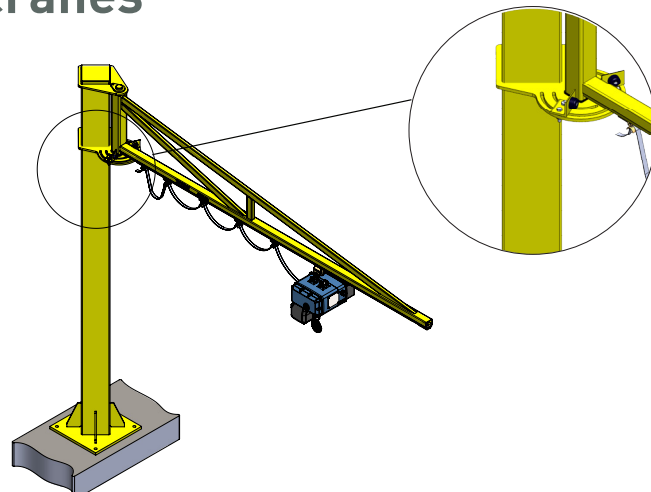

Light crane systems

We reserve the right for technical amendments without obligation.
The product pictures and drawings depicted in this catalogue do not always reflect all available sizes.

Version January 2018

www.niko.eu.com

Component Specifications

NIKO Track Profiles

Our wide range of 5 Track profile sizes can accommodate loads up to 2.000 kg. The NIKO enclosed track tapered design allows correct alignment of the trolleys and reduces the possibility of dust build up. This ensures the smooth running of the trolleys and the long life of the crane. NIKO light cranes require only 1-4% force of the weight being lifted in order to operate. For use in aggressive environments we can also offer Niko Cranes in stainless steel grade 304 and 316.

NIKO Profile No.	Dimensions			
	h (mm)	b (mm)	d (mm)	s (mm)
21.000	28.00	30.00	8.00	1.75
23.000	35.00	40.00	11.00	2.75
24.000	43.50	48.50	15.00	3.20
25.000	60.00	65.00	18.00	3.60
26.000	75.00	80.00	22.00	4.50
27.000	110.00	90.00	25.00	6.50

LIGHT CRANE SYSTEMS

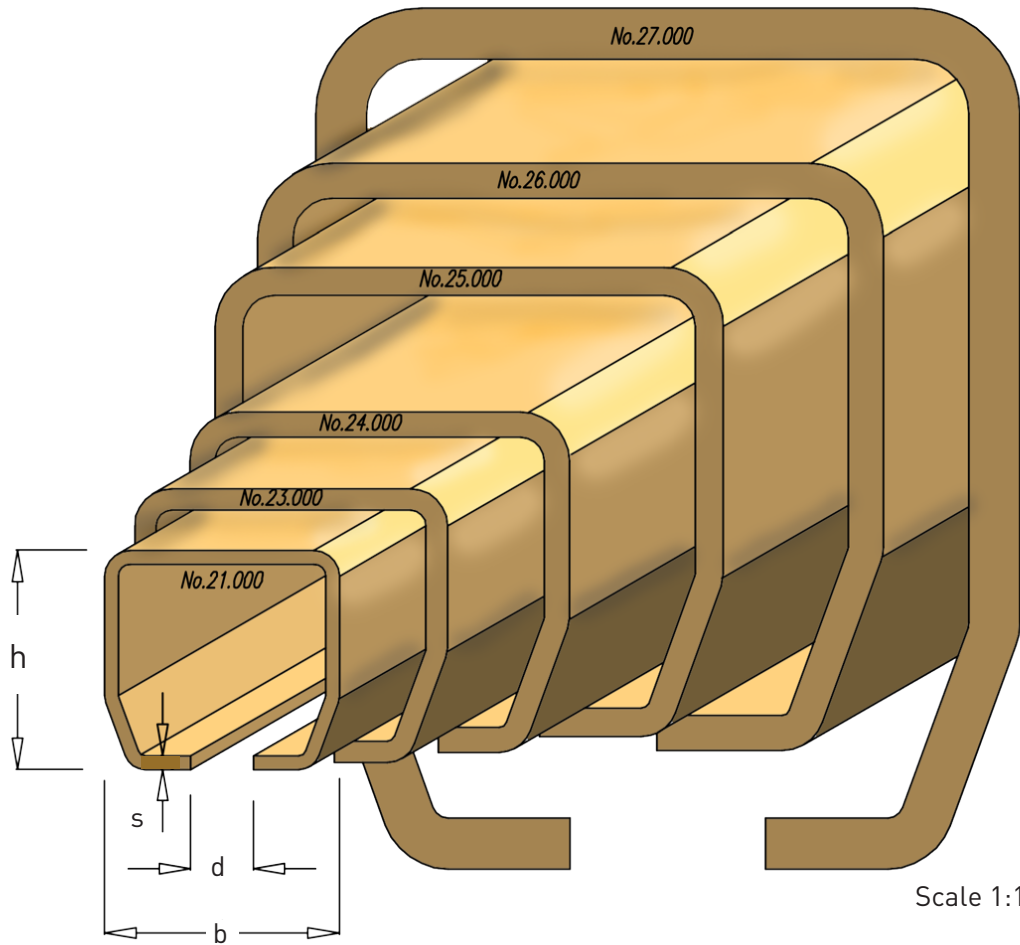

Unreinforced track (plain or zinc plated finish)

NIKO Profile No.	24.000		25.000		26.000				27.000			
P max (Kg)	80	125	80	125	250	125	250	500	750	250	500	750
L (m)	3.5	1.8	6	4.8	2.5	6	5	2.5	1.8	6	6	4.5
L1 max (mm)	650	200	1400	900	350	1250	1000	350	400	500	1000	850
L2 max (m)	2.2	1.4	3.2	3	1.8	3.5	3	1.8	1	5	4	2.8

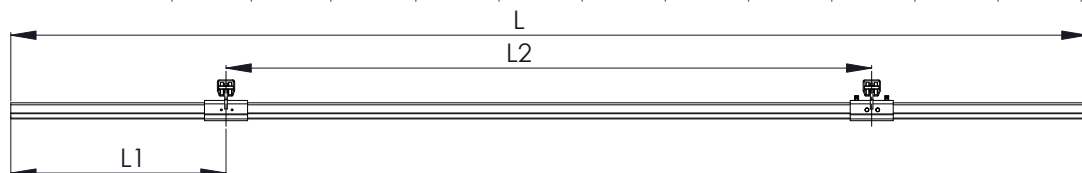

Light crane systems

We reserve the right for technical amendments without obligation. The product pictures and drawings depicted in this catalogue do not always reflect all available sizes.

Reinforced track with welded steel plate

In order to increase the bridge span and the supporting distances of the profiles we have developed 3 types of reinforced tracks. Reinforced track with welded spine is a cost effective solution for relatively short spans or supporting distances. The welded spine reinforcement is also recommended for low head room requirement due to the low height of the spine.

NIKO Profile No.	23.000	24.000		25.000	26.000		27.000	
Part No.	23.030	24.030	24.031	25.030	26.030	26.031	27.030	27.030
P max (Kg)	80	125	125	250	500	750	1000	1600
L max (m)	4	5	6	6	6	6	6	3.5
HxS (mm)	80x8	100x8	120x8	120x10	150x10	180x10	180x10	180x10
L1 (mm)	400	500	500	550	600	600	700	700

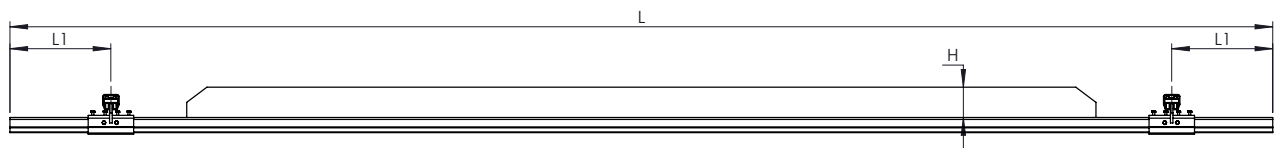
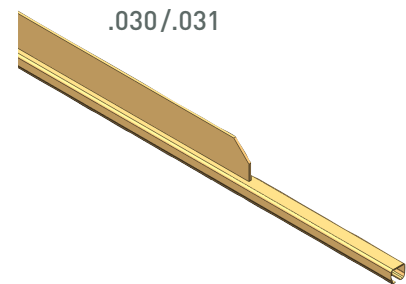

Reinforced track with welded rectangular tube (powder coated finish)

NIKO Profile No.	24.000	25.000	26.000		27.000		
Part No.	RL.24.080	RL.25.080	RL.26.080	RL.26.081	RL.27.080		
P max (Kg)	125	250	500	750	1000	1600	2000
L max (m)	7	8	8	8	8	6	5
H (mm)	100	120	160	200	200	200	200
L1 (mm)	500	550	600	600	700	700	700

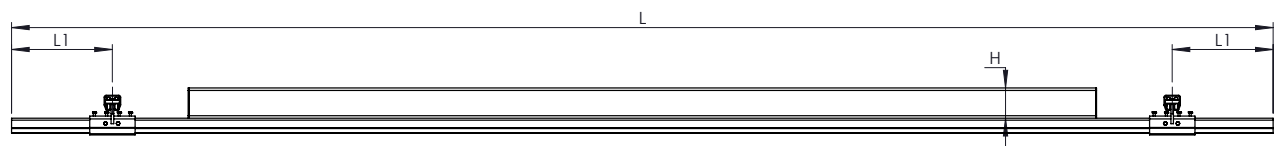
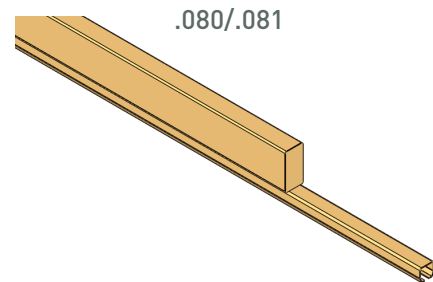

LIGHT CRANE SYSTEMS

Reinforced track with welded square profiles (AKA trussed, trellis or ladder type)

This type of reinforcements are necessary for long spans with fewer supporting points.

NIKO Profile No.	24.000	25.000	26.000		27.000		
Part No.	24.045	25.045	26.045	26.045	27.045	27.045	27.045
P max (Kg)	125	250	500	750	1000	1600	2000
L max (m)	9	10	10	10	10	10	10
H (mm)	280	320	380	380	460	460	460
L1 max (mm)	500	550	600	600	700	700	700

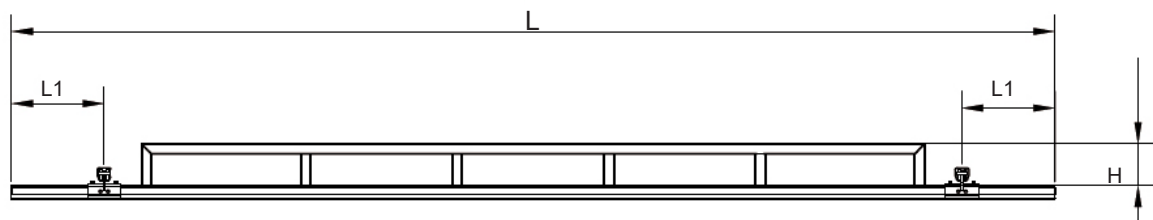
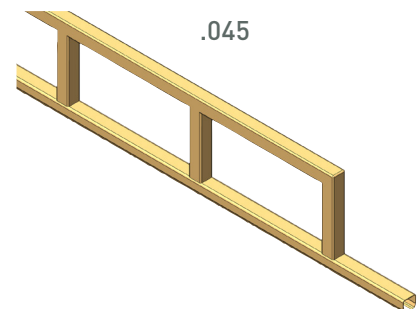

Light crane systems

We reserve the right for technical amendments without obligation.
The product pictures and drawings depicted in this catalogue do not always reflect all available sizes.

Version January 2018

www.niko.eu.com

Splice joint

.B49

The track sections are joined using the track joint by tightening the top screws first then aligning the profiles by means of the side screws.

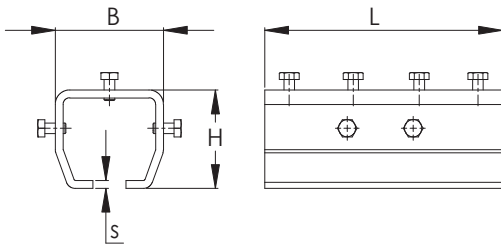
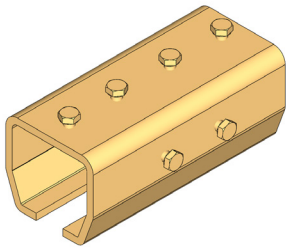

NIKO Profile No.	21.000	23.000	24.000	25.000	26.000	27.000
Part No.	21.B49	23.B49	24.B49	25.B49	26.B49	27.B49
L (mm)	85	120	150	180	200	250
H (mm)	36	44	54	75	94	133
B (mm)	38	50	61	81	100	116
s (mm)	3	4	4.5	6	8	10

Support bracket

.B00/.B50

This bracket can be used and adapted for specific applications where standard supports are unsuitable. (plain-unplated and zinc plated)

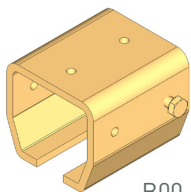

.B00

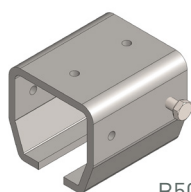

.B50

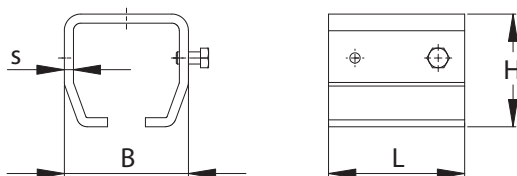

NIKO Profile No.	21.000	23.000	24.000	25.000	26.000	27.000
Part No. Zinc plated	21.B00	23.B00	24.B00	25.B00	26.B00	27.B00
Part No. Black	21.B50	23.B50	24.B50	25.B50	26.B50	27.B50
L (mm)	40	56	68	90	110	120
H (mm)	36	44	54	75	94	133
B (mm)	38	50	61	81	100	116
s (mm)	3	4	4.5	6	8	10

LIGHT CRANE SYSTEMS

Ceiling support bracket

.B02

This bracket is designed for bolting direct to overhead steelwork or ceiling.

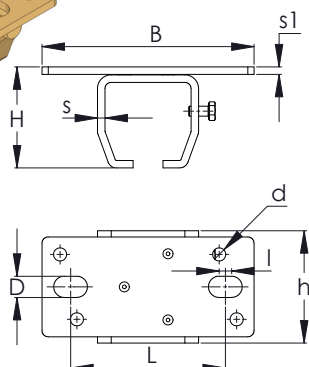
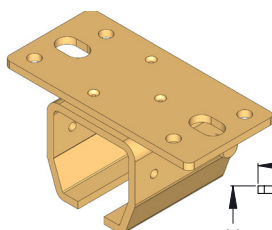

NIKO Profile No.	21.000	23.000	24.000	25.000	26.000	27.000
Part No.	21.B02	23.B02	24.B02	25.B02	26.B02	27.B02
B (mm)	90	115	130	171	210	260
H (mm)	39	50	60	81	104	145
h (mm)	40	56	68	90	110	120
D (mm)	8	11	13	17	22	22
d (mm)	5.2	6.2	8.2	11	-	-
L (mm)	64	81	94	124	148	178.5
s (mm)	3	4	4.5	6	8	10
l (mm)	7	8	8	10	12	23.5
s1 (mm)	3	4	5	6	10	12

Split support bracket

This bracket is generally used for variable height configurations.

NIKO Profile No.	21.000	23.000	24.000	25.000	26.000	27.000
Part No.	21.B03	23.B03	24.B03	25.B03	26.B03	27.B03
B (mm)	36	48	57	77	96	110
H (mm)	65	78	88	131	150	180
L (mm)	40	50	50	90	110	120
h (mm)	47	60	70	94	112	148
s (mm)	3	4	4	6	8	10
e (mm)	6	8	8	10	10	15
D (mm)	M10	M12	M12	M16	M16	M16
l (mm)	-	-	-	-	-	80

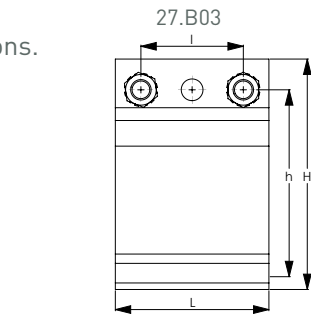

.B03

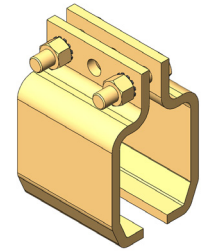

27.B03

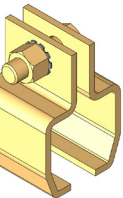
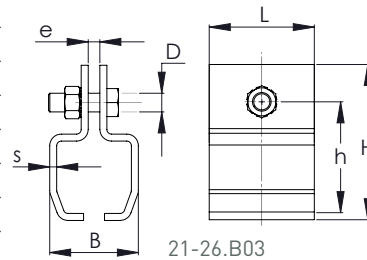

21-26.B03

Split support bracket No. B03 & plate with welded-on threaded rod

.B13

NIKO Profile No.	23.000	24.000	25.000	26.000	27.000
Part No.	23.B13	24.B13	25.B13	26.B13	27.B13
B (mm)	48	57	77	96	110
L (mm)	50	50	90	110	120
H (mm)	170	180	230	288	340
d (mm)	M12	M12	M16	M16	M16
D (mm)	M16	M16	M20	M20	M20

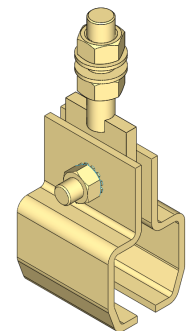
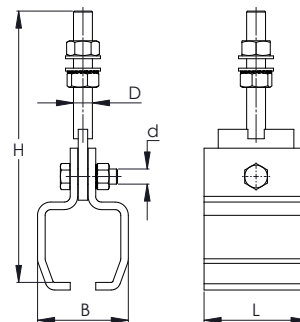

LIGHT CRANE SYSTEMS

Height adjustable support bracket

This allows us to adjust the height of the rails and to correct any misalignments.

.B04

NIKO Profile No.	21.000	23.000	24.000	25.000	26.000	27.000
Part No.	21.B04	23.B04	24.B04	25.B04	26.B04	27.B04
B (mm)	38	50	61	81	100	116
H (mm)	100	135	146	215	295	348
L (mm)	40	56	68	90	110	120
D (mm)	M10	M16	M16	M20	M20	M30
h max (mm)	32	50	55	93	140	140
s (mm)	3	4	4.5	6	8	10
l (mm)	16	20	30	40	50	43

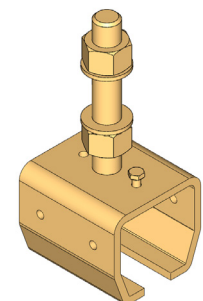
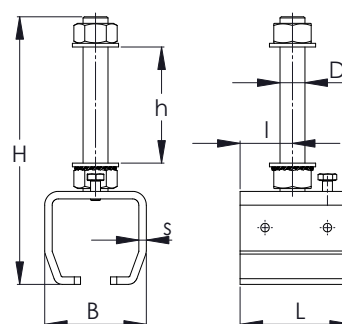

Light crane systems

We reserve the right for technical amendments without obligation.
The product pictures and drawings depicted in this catalogue do not always reflect all available sizes.

Version January 2018

www.niko.eu.com

Adjustable wall bracket

.B05

This is used in combination with the .B04 adjustable bracket and it usually mounted on the wall.

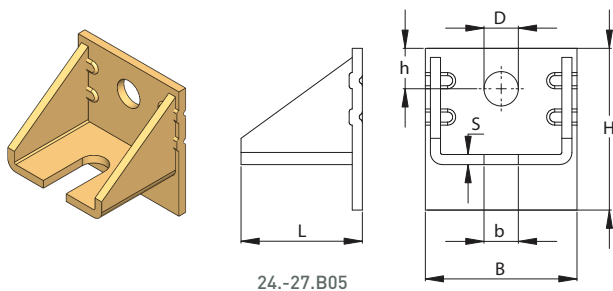

24.-27.B05

NIKO Profile No.	21.000	23./24.000	25./26.000
Part No.	21.B05	24.B05	26.B05
B (mm)	50	75	90
H (mm)	40	80	110
L (mm)	49	60	98
s (mm)	5	5	8
b (mm)	10.5	17	21
D (mm)	13	17	18
h (mm)	15	20	26

Double adjustable wall bracket

.B06

It can accommodate two .B04 adjustable brackets.

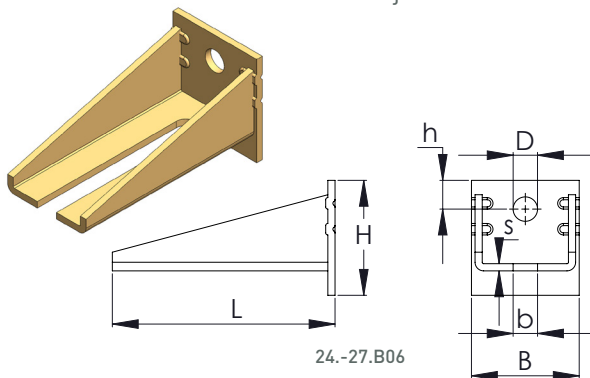

24.-27.B06

NIKO Profile No.	21.000	23./24.000	25.000	26.000	27.000
Part No.	21.B06	24.B06	25.B06	26.B06	27.B06
B (mm)	60	75	90	90	90
H (mm)	50	80	110	110	110
h (mm)	15	20	26	26	26
L (mm)	100	155	208	208	208
s (mm)	6	5	8	8	8
b (mm)	10.5	17	21	21	32
D (mm)	13	17	18	18	22

21.B05

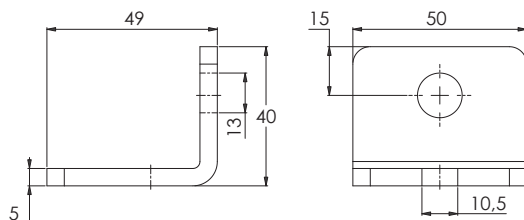

21.B06

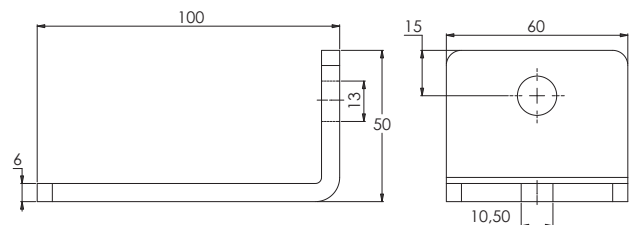

Split suspension bracket

.B08/.B26

This bracket is used for mounting directly to the underside flange of a parallel I beam.

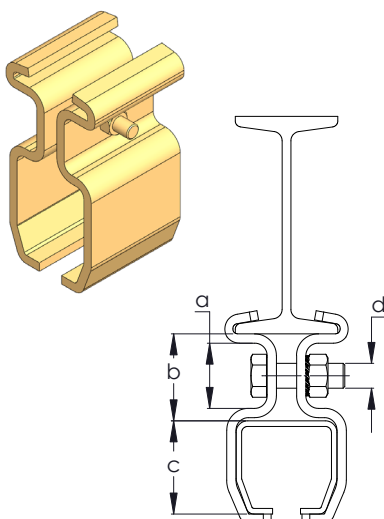

NIKO Profile No.	23.000	24.000	25.000	26.000	27.000
Dimension a in mm.	25	25	42	45	66
Dimension b in mm.	34	34	56	63	90
Dimension c in mm.	35	43.5	60	75	110
Dimension d in mm.	9 Φ	9 Φ	17 Φ	17 Φ	17 Φ
Screw type	M8x30	M8x30	M16x50	M16x50	M16x50
Material	50x4	50x4	90x6	110x8	120x10
Split Suspension Bracket Joist IPN DIN 1025					
For IPN 80x42 (IPE 80)	23.B08	24.B08			
For IPN 100x50 (IPE 80)	23.B10	24.B10	25.B10		
For IPN 120x58 (IPE 100)	23.B12	24.B12	25.B12		
For IPN 140x66 (IPE 120)	23.B14	24.B14	25.B14		
For IPN 160x74 (IPE 140)		24.B16	25.B16	26.B16	
For IPN 180x82 (IPE 160)		24.B18	25.B18	26.B18	
For IPN 200x90 (IPE 180)		24.B20	25.B20	26.B20	27.B20
For IPN 220x98 (IPE 200)			25.B22	26.B22	27.B22
For IPN 240x106 (IPE 220)			25.B24	26.B24	27.B24
For IPN 260x113 (IPE 240)			25.B26	26.B26	27.B26

Ceiling support / Splice joint

.B30

This is a combination of a ceiling support and a splice joint.

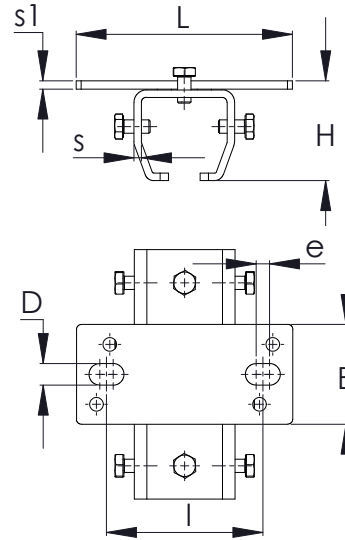
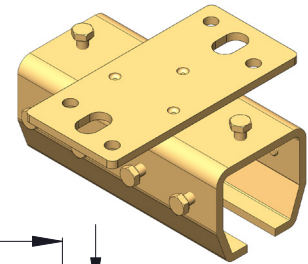

NIKO Profile No.	21.000	23.000	24.000	25.000	26.000	27.000
Part No.	21.B30	23.B30	24.B30	25.B30	26.B30	27.B30
L (mm)	90	115	130	171	210	260
H (mm)	39	50	60	81	104	145
s (mm)	3	4	4.5	6	8	10
B (mm)	40	50	60	80	100	120
e (mm)	7	8	8	10	12	23.5
l (mm)	64	81	94	124	148	178.5
D (mm)	8	11	13	17	22	22
s1 (mm)	3	4	5	6	10	12

Height adjustable support / Splice joint

.B11

This is a combination of a height adjustable bracket and a splice joint.

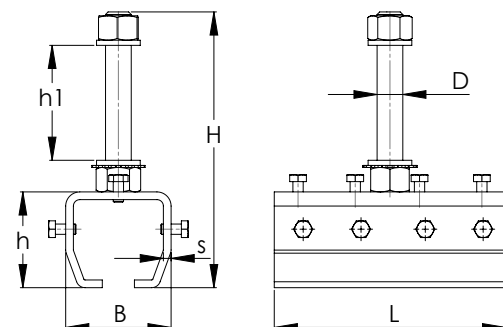
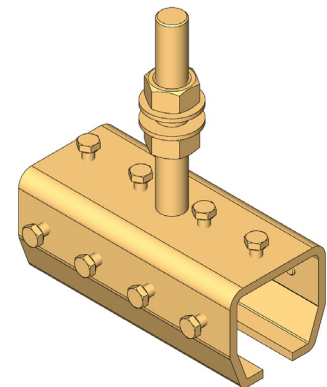

NIKO Profile No.	21.000	23.000	24.000	25.000	26.000	27.000
Part No.	21.B11	23.B11	24.B11	25.B11	26.B11	27.B11
B (mm)	38	50	61	81	100	116
H (mm)	100	135	146	215	295	348
D (mm)	M10	M16	M16	M20	M20	M30
L (mm)	85	120	150	180	200	250
h (mm)	36	44	54	75	94	133
h1 max (mm)	32	50	55	93	140	140
s (mm)	3	4	4.5	6	8	10

LIGHT CRANE SYSTEMS

Light crane systems

We reserve the right for technical amendments without obligation.
The product pictures and drawings depicted in this catalogue do not always reflect all available sizes.

Version January 2018

www.niko.eu.com

Height adjustable bracket IPN DIN 1025 .B55/.B56

.B55
parallel to the I-beam

.B56
vertical to the I-beam

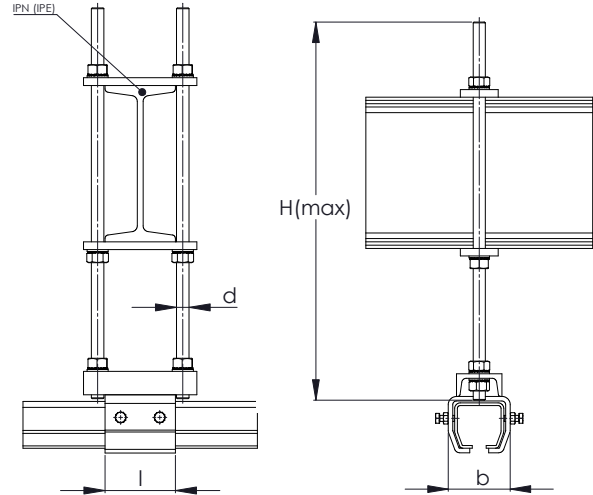
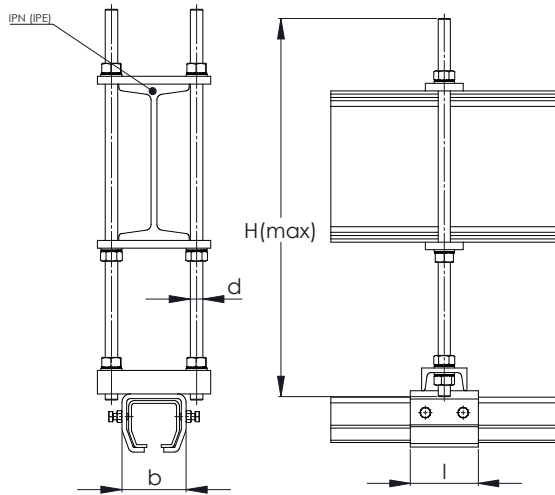

LIGHT CRANE SYSTEMS

.B55

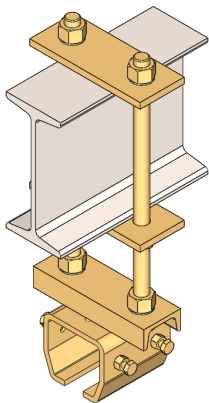

.B56

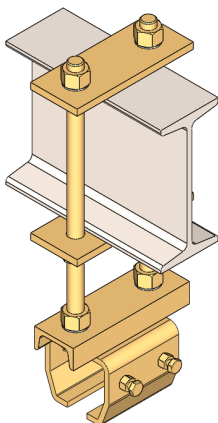

NIKO Profile No.	23.000	24.000	25.000	26.000	27.000
Bracket No. for IPN 80 (IPE 80)	23.B55.080 23.B56.080	24.B55.080 24.B56.080			
Bracket No. for IPN 100 (IPE 80)	23.B55.100 23.B56.100	24.B55.100 24.B56.100	25.B55.100 25.B56.100		
Bracket No. for IPN 120 (IPE 100)	23.B55.120 23.B56.120	24.B55.120 24.B56.120	25.B55.120 25.B56.120		
Bracket No. for IPN 140 (IPE 120)	23.B55.140 23.B56.140	24.B55.140 24.B56.140	25.B55.140 25.B56.140		
Bracket No. for IPN 160 (IPE 140)		24.B55.160 24.B56.160	25.B55.160 25.B56.160	26.B55.160 26.B56.160	
Bracket No. for IPN 180 (IPE 160)		24.B55.180 24.B56.180	25.B55.180 25.B56.180	26.B55.180 26.B56.180	
Bracket No. for IPN 200 (IPE 180)		24.B55.200 24.B56.200	25.B55.200 25.B56.200	26.B55.200 26.B56.200	27.B55.200 27.B56.200
Bracket No. for IPN 220 (IPE 200)			25.B55.220 25.B56.220	26.B55.220 26.B56.220	27.B55.220 27.B56.220
Bracket No. for IPN 240 (IPE 220)			25.B55.240 25.B56.240	26.B55.240 26.B56.240	27.B55.240 27.B56.240
Bracket No. for IPN 260 (IPE 240)			25.B55.260 25.B56.260	26.B55.260 26.B56.260	27.B55.260 27.B56.260
b (mm)	50	61	81	100	116
l (mm)	56	68	90	110	120
H max (mm)	500	500	500	500	500
d (mm)	M12	M16	M16	M20	M20

Adjustable joist clamp with support bracket (Parallel and 90° to the I-beam)

.B35/.B36

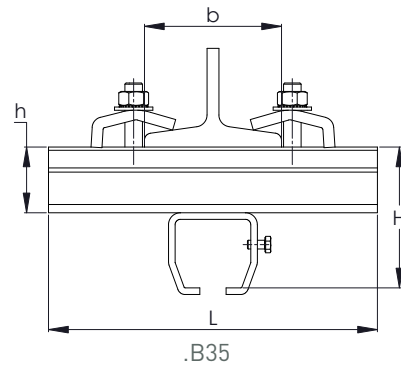
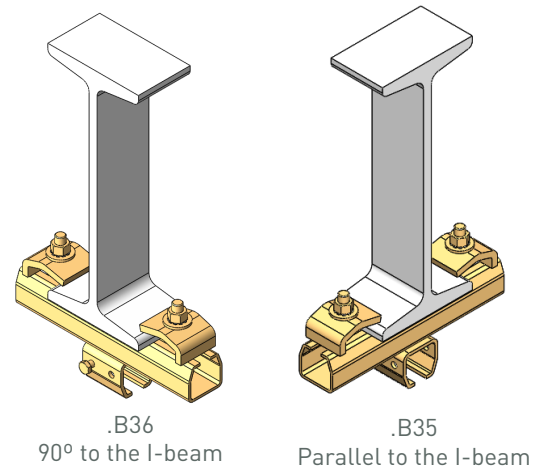
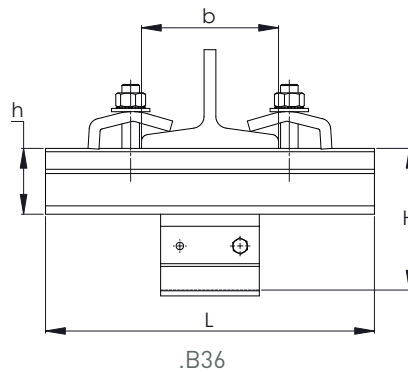

NIKO Profile No.	23.000	24.000	25.000	26.000	27.000
Part No.	23.B35	24.B35	25.B35	26.B35	27.B35
Part No.	23.B36	24.B36	25.B36	26.B36	27.B36
H (mm)	85	94	129	146	199
L (mm)	250	250	300	300	330
b max (mm)	150	150	175	175	205
h (mm)	43.5	43.5	60	60	75

LIGHT CRANE SYSTEMS

Adjustable joist clamp with splice joint (Parallel and 90° to the I-beam)

.B71/.B72

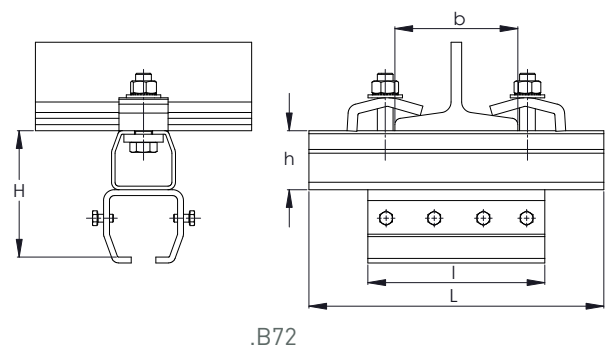
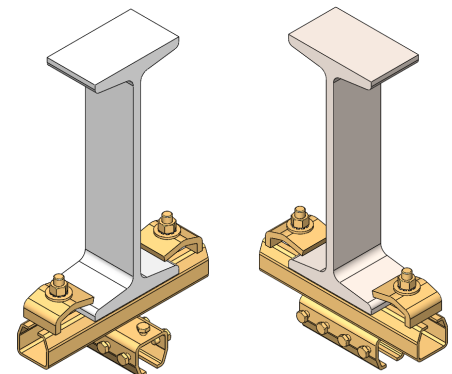
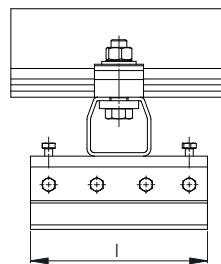
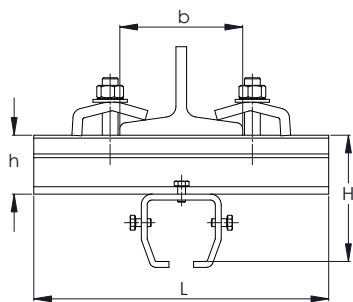

NIKO Profile No.	23.000	24.000	25.000	26.000	27.000
Part No.	23.B71	24.B71	25.B71	26.B71	27.B71
Part No.	23.B72	24.B72	25.B72	26.B72	27.B72
H (mm)	85	94	129	146	199
h (mm)	43.5	43.5	60	60	75
l (mm)	120	150	180	200	250
L (mm)	250	250	300	300	330
b max (mm)	150	150	175	175	205

Light crane systems

We reserve the right for technical amendments without obligation.
The product pictures and drawings depicted in this catalogue do not always reflect all available sizes.

I-Beam girder clamp

.B37

This item is used for clamping the adjustable suspension bracket to the support steelwork and is supplied with a bolt and square nut.

23.- 25.B37

21.B37

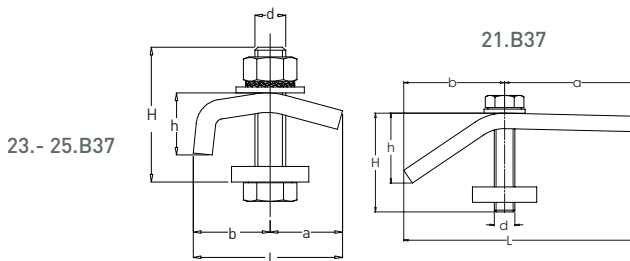
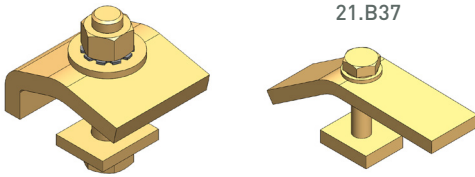

NIKO Profile No.	21.000	23./24.000	25./26.000
Part No.	21.B37	23.B37	25.B37
l (mm)	90	62	80
a (mm)	50	30	40
b (mm)	40	32	40
h (mm)	26	24	30
d (mm)	M8	M12	M16
H (mm)	40	60	70

Girder clamp (heavy duty)

.Z37

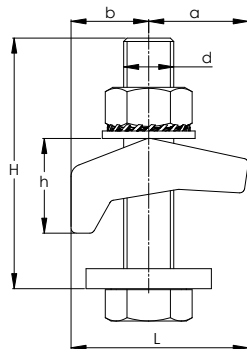
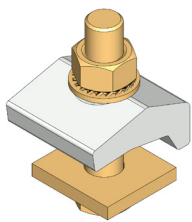

NIKO Profile No.	21.000	23./24.000	25./26.000	27.000
Part No.	21.Z37	23.Z37	25.Z37	27.Z37
H (mm)	50	60	70	100
a (mm)	20	24	32	40
b (mm)	16	19	25	31
d (mm)	M10	M12	M16	M20
h (mm)	20	23	30	38
L (mm)	36	43	57	71

Adjustable suspension bracket

.B38

These brackets are designed to accommodate variations in support steelwork distances relative to the track level. They are normally used in conjunction with the split support brackets.

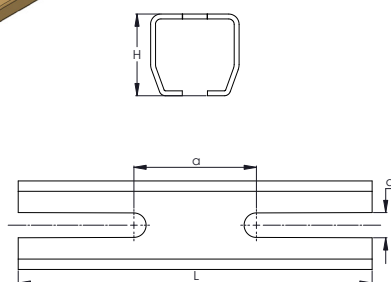
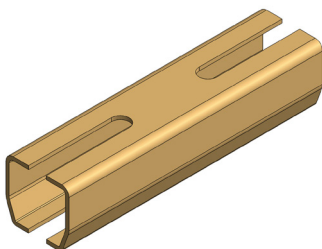

NIKO Profile No.	23.000	24.000	25.000	26.000
Part No.	23.B38		25.B38	
L (mm)	198		250	
a (mm)	76		80	
d (mm)	12.5		18	
H (mm)	35		60	

Adjustable suspension bracket

.B39

This item is used for clamping the adjustable suspension bracket to the support steelwork and is supplied with a bolt and square nut.

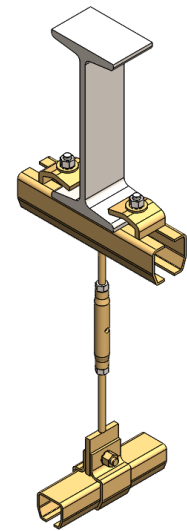
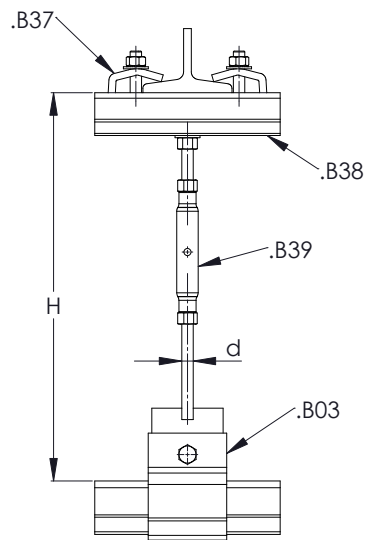

NIKO Profile No.	23.000	24.000	25.000	26.000
Part No.	23.B39	24.B39	25.B39	26.B39
H max (mm)	375	585	600	
H min (mm)	265	410	425	
d (mm)	M12	M16	M16	

Adjustable bracket with ceiling support

.B44

NIKO Profile No.	23.000	24.000	25.000	26.000	27.000
Part No.	23.B44	24.B44	25.B44	26.B44	27.B44
B (mm)	50	50	50	80	80
H (mm)	70	70	70	100	100
L (mm)	200	200	200	280	300
D (mm)	M16	M16	M20	M20	M30
e (mm)	15	15	15	18	20
d (mm)	11	11	11	21	21
H1 max (mm)	100	110	175	255	300
H1 min (mm)	50	55	85	115	160

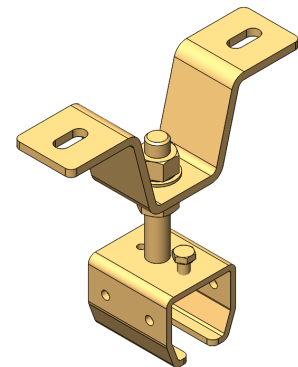
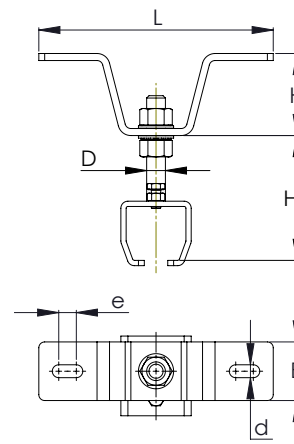

LIGHT CRANE SYSTEMS

Ceiling support

.Z08

NIKO Profile No.	23/24.000	25.000	26.000	27.000
Part No.	23/24.Z08	25.Z08	26.Z08	27.Z08
B (mm)	50	50	80	80
H (mm)	70	70	100	100
L (mm)	200	200	280	300
D (mm)	17	21	21	31
e (mm)	15	15	18	20
d (mm)	11	11	21	21
l (mm)	150	150	220	240

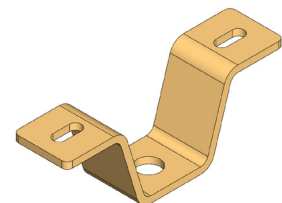
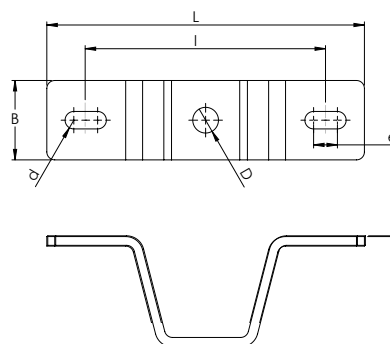

Light crane systems

We reserve the right for technical amendments without obligation.
The product pictures and drawings depicted in this catalogue do not always reflect all available sizes.

Suspension bracket

.B40

This is normally connected with a steel plate to the bracket B03.

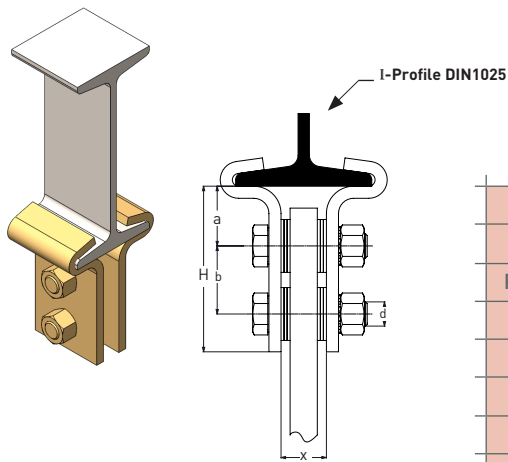

NIKO Profile No.	24.000	24.000 & 25.000		25.000 & 26.000		
Part No.	24.B40	24.B40		26.B40		
Profile DIN 1025 IPN	100	120	140	160	180	200
X (mm)	8	16	24	14	22	30
a (mm)	33	33		40		
b (mm)	45	45		45		
d (mm)	M12	M12		M16		
H (mm)	98	98		110		

Support bracket for reinforced track .045

.Z01

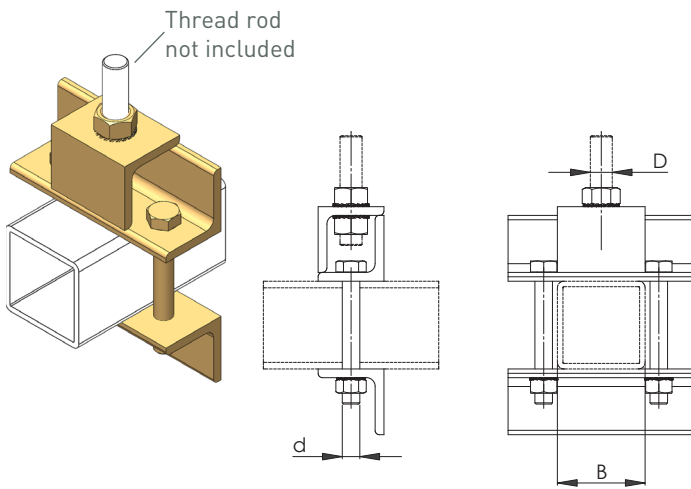

NIKO Profile No.	24.000	25.000	26.000	27.000
Part No.	24.Z01	25.Z01	26.Z01	27.Z01
B (mm)	50	60	80	100
D (mm)	M16	M20	M20	M30
d (mm)	M12	M16	M16	M20

LIGHT CRANE SYSTEMS

Thread rod with nuts and serrated washers

.Z02

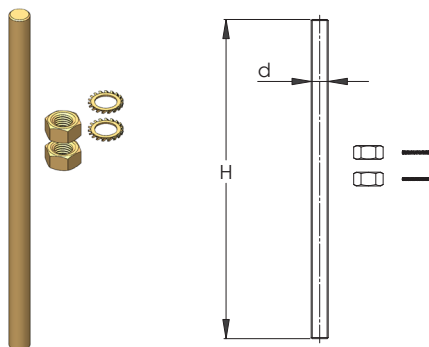

NIKO Profile No.	24.000	25.000
Part No.	24.Z02	25.Z02
H (mm)	500	500
d (mm)	M16	M20

Support bracket with welded square tube

.Z03

NIKO Profile No.	24.000	25.000	26.000	27.000
Part No.	24.Z03	25.Z03	26.Z03	27.Z03
B (mm)	61	81	100	116
L (mm)	68	90	110	120
H (mm)	114	155	174	233
d (mm)	M16	M20	M20	M30

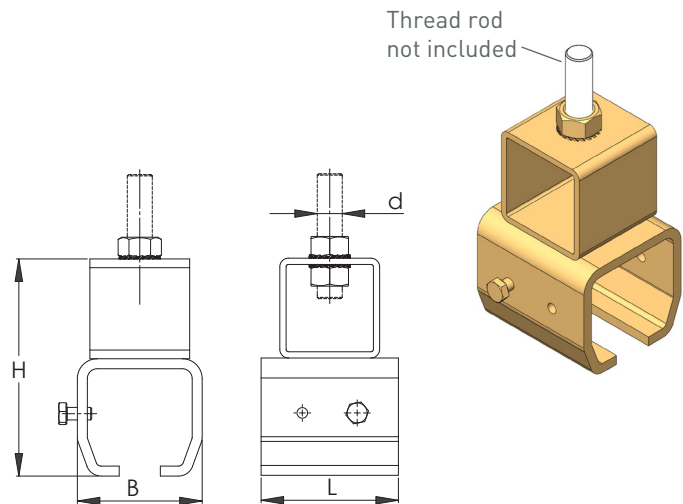
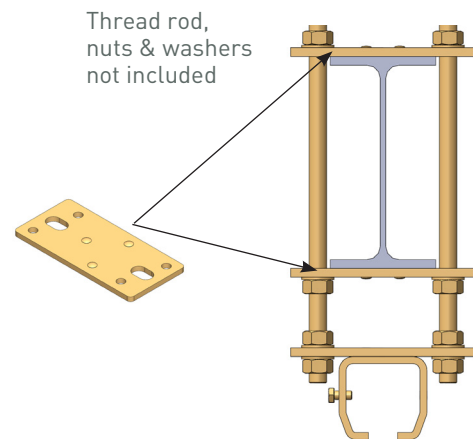
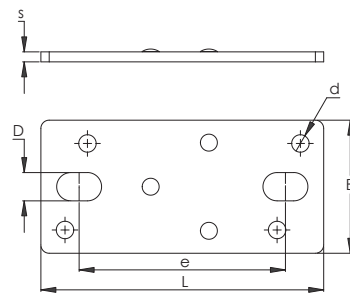

Plate for ceiling support bracket

.B09

NIKO Profile No.	23.000	24.000	25.000	26.000	27.000
Part No.	23.B09	24.B09	25.B09	26.B09	27.B09
L (mm)	115	130	171	210	260
B (mm)	50	60	80	100	120
e (mm)	81	94	124	148	178,5
D (mm)	11	13	17	22	22
s (mm)	4	5	6	10	12
d (mm)	6.2	8.2	11	-	-



LIGHT CRANE SYSTEMS

Sway brace fittings

.Z05/.Z06

NIKO Profile No.	23.000 & 24.000	25.000 & 26.000	27.000
Part No.	23.Z05	25.Z05	27.Z05

NIKO Profile No.	23.000 & 24.000	25.000 & 26.000	27.000
Part No.	23.Z06	25.Z06	27.Z06

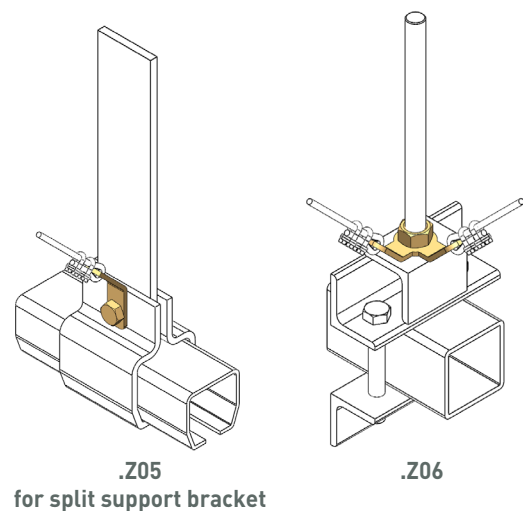

Light crane systems

We reserve the right for technical amendments without obligation.
The product pictures and drawings depicted in this catalogue do not always reflect all available sizes.

Plate with welded-on threaded rod

.Z07

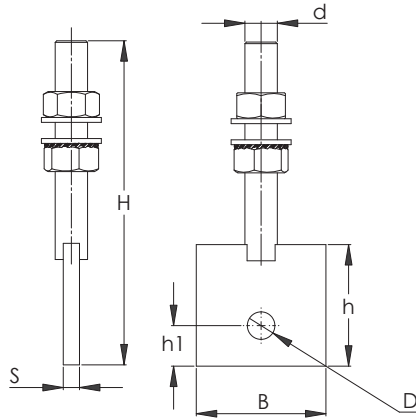
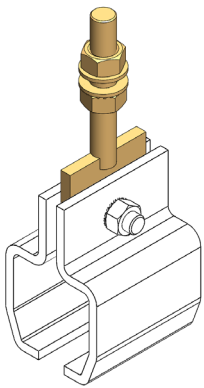

NIKO Profile No.	24.000	25.000	26.000	27.000
Part No.	24.Z07	25.Z07	26.Z07	27.Z07
B (mm)	50	60	80	120
H (mm)	131	160	200	216
s (mm)	8	10	10	15
d (mm)	M16	M20	M20	M30
h1 (mm)	20	25	25	24
h (mm)	50	77	75	75
D (mm)	12	16	16	16

Ceiling support bracket with spacer

.Z09

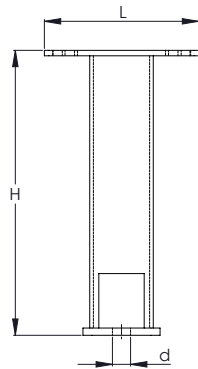
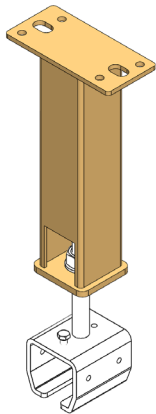

NIKO Profile No.	24.000		25.000		26.000		27.000	
Part No.	24.Z09.050	24.Z09.100	25.Z09.050	25.Z09.100	26.Z09.050	26.Z09.100	27.Z09.050	27.Z09.100
L (mm)	130		171		210		260	
d (mm)	M16		M20		M20		M30	
H (mm)	500	1000	500	1000	500	1000	500	1000

Adjustable bracket for I-Beam

.Z10

NIKO Profile No.	24.000	25.000	26.000	27.000
Bracket No. for IPN 80 (IPE 80)	24.Z10.080			
Bracket No. for IPN 100 (IPE 80)	24.Z10.100	25.Z10.100		
Bracket No. for IPN 120 (IPE 100)	24.Z10.120	25.Z10.120		
Bracket No. for IPN 140 (IPE 120)	24.Z10.140	25.Z10.140		
Bracket No. for IPN 160 (IPE 140)	24.Z10.160	25.Z10.160	26.Z10.160	27.Z10.160
Bracket No. for IPN 180 (IPE 160)	24.Z10.180	25.Z10.180	26.Z10.180	27.Z10.180
Bracket No. for IPN 200 (IPE 180)	24.Z10.200	25.Z10.200	26.Z10.200	27.Z10.200
Bracket No. for IPN 220 (IPE 200)		25.Z10.220	26.Z10.220	27.Z10.220
Bracket No. for IPN 240 (IPE 220)		25.Z10.240	26.Z10.240	27.Z10.240
Bracket No. for IPN 260 (IPE 240)		25.Z10.260	26.Z10.260	27.Z10.260
B (mm)	61	81	100	116
L (mm)	68	90	110	120
H (mm)	150±25	180±25	205±25	235±25
d (mm)	M16	M16	M20	M20
s (mm)	8	10	10	12

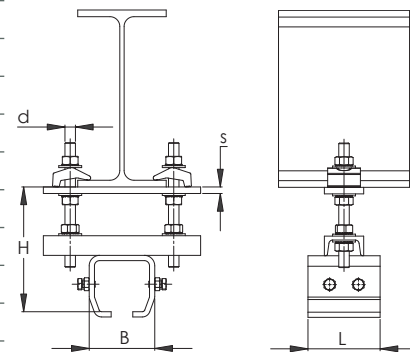
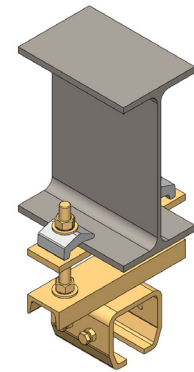

Mounting assembly with plates for I-Beam

.Z11

NIKO Profile No.	24.000	25.000	26.000	27.000
Bracket No. for IPN 80 (IPE 80)	24.Z11.080			
Bracket No. for IPN 100 (IPE 80)	24.Z11.100	25.Z11.100		
Bracket No. for IPN 120 (IPE 100)	24.Z11.120	25.Z11.120		
Bracket No. for IPN 140 (IPE 120)	24.Z11.140	25.Z11.140		
Bracket No. for IPN 160 (IPE 140)	24.Z11.160	25.Z11.160	26.Z11.160	27.Z11.160
Bracket No. for IPN 180 (IPE 160)	24.Z11.180	25.Z11.180	26.Z11.180	27.Z11.180
Bracket No. for IPN 200 (IPE 180)	24.Z11.200	25.Z11.200	26.Z11.200	27.Z11.200
Bracket No. for IPN 220 (IPE 200)		25.Z11.220	26.Z11.220	27.Z11.220
Bracket No. for IPN 240 (IPE 220)		25.Z11.240	26.Z11.240	27.Z11.240
Bracket No. for IPN 260 (IPE 240)		25.Z11.260	26.Z11.260	27.Z11.260
B (mm)	50	60	80	100
H (mm)	56	68	90	112
s (mm)	6	8	10	12
d (mm)	M10	M12	M16	M20

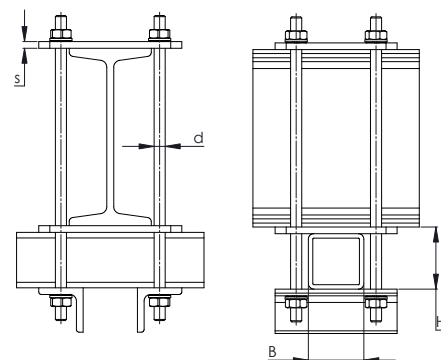
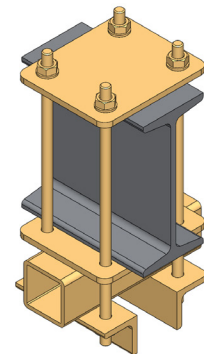

LIGHT CRANE SYSTEMS

Light crane systems

We reserve the right for technical amendments without obligation.
The product pictures and drawings depicted in this catalogue do not always reflect all available sizes.

Version January 2018

www.niko.eu.com

Support bracket with clamps for I-Beam

.Z13

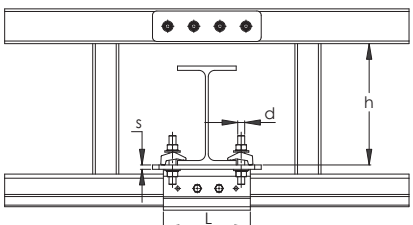
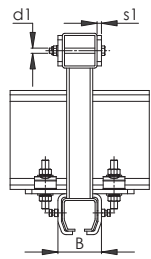
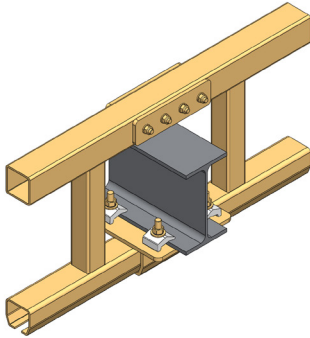

NIKO Profile No.	24.000	25.000	26.000	27.000
Bracket No. for IPN 80 (IPE 80)	24.Z13.080			
Bracket No. for IPN 100 (IPE 80)	24.Z13.100	25.Z13.100		
Bracket No. for IPN 120 (IPE 100)	24.Z13.120	25.Z13.120		
Bracket No. for IPN 140 (IPE 120)	24.Z13.140	25.Z13.140		
Bracket No. for IPN 160 (IPE 140)	24.Z13.160	25.Z13.160	26.Z13.160	27.Z13.160
Bracket No. for IPN 180 (IPE 160)	24.Z13.180	25.Z13.180	26.Z13.180	27.Z13.180
Bracket No. for IPN 200 (IPE 180)	24.Z13.200	25.Z13.200	26.Z13.200	27.Z13.200
Bracket No. for IPN 220 (IPE 200)		25.Z13.220	26.Z13.220	27.Z13.220
Bracket No. for IPN 240 (IPE 220)		25.Z13.240	26.Z13.240	27.Z13.240
Bracket No. for IPN 260 (IPE 240)		25.Z13.260	26.Z13.260	27.Z13.260
B (mm)	61	81	100	116
L (mm)	150	180	200	250
d (mm)	M12	M16	M16	M20
s (mm)	6	8	10	12
h (mm)	230	260	300	360
d1 (mm)	M10	M10	M12	M16
s1 (mm)	6	8	10	12

LIGHT CRANE SYSTEMS

Height adjustable splice joint for I-Beam

.Z16

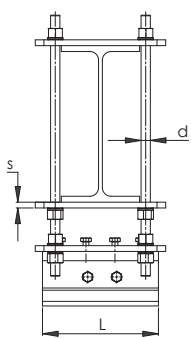
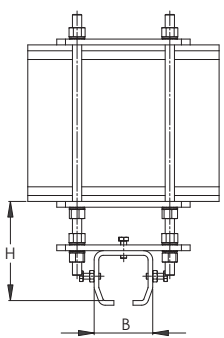
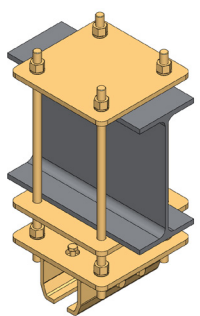

NIKO Profile No.	24.000	25.000	26.000	27.000
Bracket No. for IPN 80 (IPE 80)	24.Z16.080			
Bracket No. for IPN 100 (IPE 80)	24.Z16.100	25.Z16.100		
Bracket No. for IPN 120 (IPE 100)	24.Z16.120	25.Z16.120		
Bracket No. for IPN 140 (IPE 120)	24.Z16.140	25.Z16.140		
Bracket No. for IPN 160 (IPE 140)	24.Z16.160	25.Z16.160	26.Z16.160	27.Z16.160
Bracket No. for IPN 180 (IPE 160)	24.Z16.180	25.Z16.180	26.Z16.180	27.Z16.180
Bracket No. for IPN 200 (IPE 180)	24.Z16.200	25.Z16.200	26.Z16.200	27.Z16.200
Bracket No. for IPN 220 (IPE 200)		25.Z16.220	26.Z16.220	27.Z16.220
Bracket No. for IPN 240 (IPE 220)		25.Z16.240	26.Z16.240	27.Z16.240
Bracket No. for IPN 260 (IPE 240)		25.Z16.260	26.Z16.260	27.Z16.260
B (mm)	61	81	100	116
L (mm)	150	180	200	250
H (mm)	126±25	155±25	186±25	232±25
s (mm)	6	8	10	12
d (mm)	M10	M12	M16	M20

Mounting assembly with clamps for I-Beam

.Z18

NIKO Profile No.	24.000	25.000	26.000	27.000
Bracket No. for IPN 80 (IPE 80)	24.Z18.080			
Bracket No. for IPN 100 (IPE 80)	24.Z18.100	25.Z18.100		
Bracket No. for IPN 120 (IPE 100)	24.Z18.120	25.Z18.120		
Bracket No. for IPN 140 (IPE 120)	24.Z18.140	25.Z18.140		
Bracket No. for IPN 160 (IPE 140)	24.Z18.160	25.Z18.160	26.Z18.160	27.Z18.160
Bracket No. for IPN 180 (IPE 160)	24.Z18.180	25.Z18.180	26.Z18.180	27.Z18.180
Bracket No. for IPN 200 (IPE 180)	24.Z18.200	25.Z18.200	26.Z18.200	27.Z18.200
Bracket No. for IPN 220 (IPE 200)		25.Z18.220	26.Z18.220	27.Z18.220
Bracket No. for IPN 240 (IPE 220)		25.Z18.240	26.Z18.240	27.Z18.240
Bracket No. for IPN 260 (IPE 240)		25.Z18.260	26.Z18.260	27.Z18.260
B (mm)	50	60	80	100
H (mm)	56	68	90	112
s (mm)	6	8	10	12
d (mm)	M12	M16	M16	M20

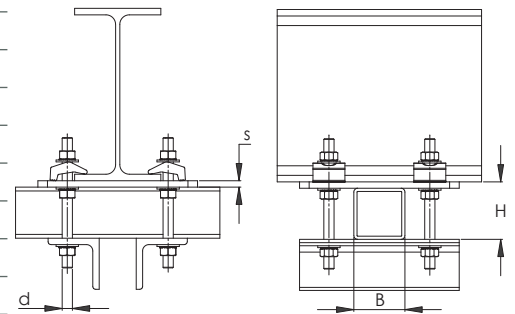
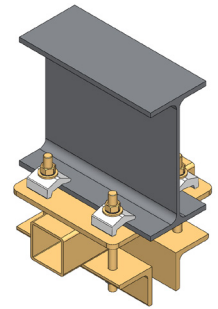

Height adjustable mounting assembly with clamps for I-Beam

.Z19

NIKO Profile No.	24.000	25.000	26.000	27.000
Bracket No. for IPN 80 (IPE 80)	24.Z19.080			
Bracket No. for IPN 100 (IPE 80)	24.Z19.100	25.Z19.100		
Bracket No. for IPN 120 (IPE 100)	24.Z19.120	25.Z19.120		
Bracket No. for IPN 140 (IPE 120)	24.Z19.140	25.Z19.140		
Bracket No. for IPN 160 (IPE 140)	24.Z19.160	25.Z19.160	26.Z19.160	27.Z19.160
Bracket No. for IPN 180 (IPE 160)	24.Z19.180	25.Z19.180	26.Z19.180	27.Z19.180
Bracket No. for IPN 200 (IPE 180)	24.Z19.200	25.Z19.200	26.Z19.200	27.Z19.200
Bracket No. for IPN 220 (IPE 200)		25.Z19.220	26.Z19.220	27.Z19.220
Bracket No. for IPN 240 (IPE 220)		25.Z19.240	26.Z19.240	27.Z19.240
Bracket No. for IPN 260 (IPE 240)		25.Z19.260	26.Z19.260	27.Z19.260
B (mm)	50	60	80	100
H (mm)	127±25	146±25	180±25	210±25
s (mm)	6	8	10	12
d (mm)	M12	M16	M16	M20

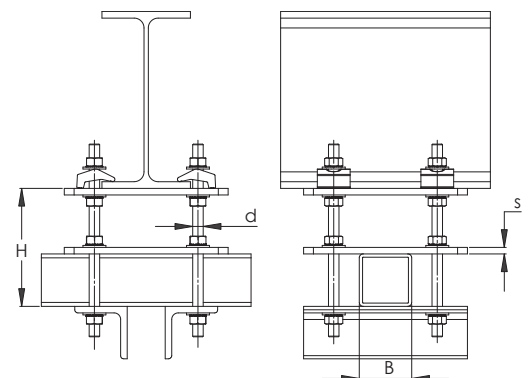
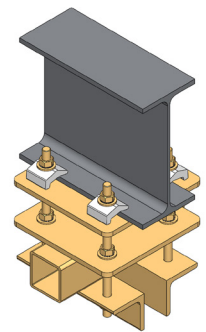

LIGHT CRANE SYSTEMS

Light crane systems

We reserve the right for technical amendments without obligation.
The product pictures and drawings depicted in this catalogue do not always reflect all available sizes.

Version January 2018

www.niko.eu.com

Height adjustable support bracket with clamps for I-Beam

.Z20

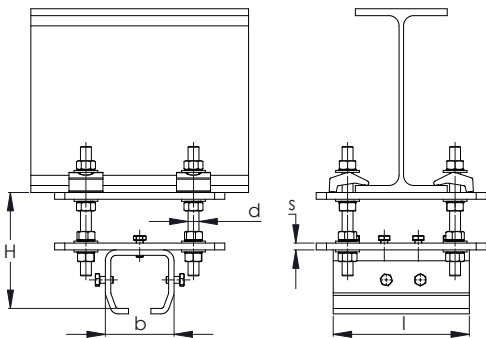
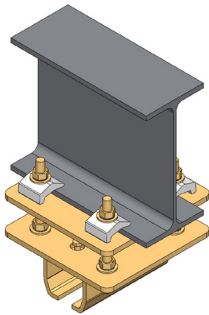

NIKO Profile No.	24.000	25.000	26.000	27.000
Bracket No. for IPN 80 (IPE 80)	24.Z20.080			
Bracket No. for IPN 100 (IPE 80)	24.Z20.100	25.Z20.100		
Bracket No. for IPN 120 (IPE 100)	24.Z20.120	25.Z20.120		
Bracket No. for IPN 140 (IPE 120)	24.Z20.140	25.Z20.140		
Bracket No. for IPN 160 (IPE 140)	24.Z20.160	25.Z20.160	26.Z20.160	27.Z20.160
Bracket No. for IPN 180 (IPE 160)	24.Z20.180	25.Z20.180	26.Z20.180	27.Z20.180
Bracket No. for IPN 200 (IPE 180)	24.Z20.200	25.Z20.200	26.Z20.200	27.Z20.200
Bracket No. for IPN 220 (IPE 200)		25.Z20.220	26.Z20.220	27.Z20.220
Bracket No. for IPN 240 (IPE 220)		25.Z20.240	26.Z20.240	27.Z20.240
Bracket No. for IPN 260 (IPE 240)		25.Z20.260	26.Z20.260	27.Z20.260
b (mm)	61	81	100	116
l (mm)	150	180	200	250
H (mm)	126±25	155±25	186±25	232±25
d (mm)	M12	M16	M16	M20
s (mm)	6	8	10	12

LIGHT CRANE SYSTEMS

Height adjustable mounting assembly with plates for I-Beam

.Z21

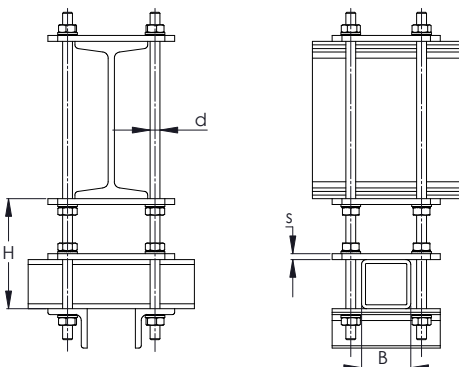
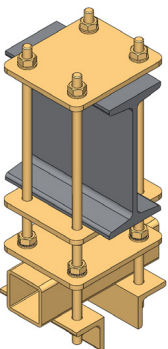

NIKO Profile No.	24.000	25.000	26.000	27.000
Bracket No. for IPN 80 (IPE 80)	24.Z21.080			
Bracket No. for IPN 100 (IPE 80)	24.Z21.100	25.Z21.100		
Bracket No. for IPN 120 (IPE 100)	24.Z21.120	25.Z21.120		
Bracket No. for IPN 140 (IPE 120)	24.Z21.140	25.Z21.140		
Bracket No. for IPN 160 (IPE 140)	24.Z21.160	25.Z21.160	26.Z21.160	27.Z21.160
Bracket No. for IPN 180 (IPE 160)	24.Z21.180	25.Z21.180	26.Z21.180	27.Z21.180
Bracket No. for IPN 200 (IPE 180)	24.Z21.200	25.Z21.200	26.Z21.200	27.Z21.200
Bracket No. for IPN 220 (IPE 200)		25.Z21.220	26.Z21.220	27.Z21.220
Bracket No. for IPN 240 (IPE 220)		25.Z21.240	26.Z21.240	27.Z21.240
Bracket No. for IPN 260 (IPE 240)		25.Z21.260	26.Z21.260	27.Z21.260
B (mm)	50	60	80	100
H (mm)	127±25	146±25	180±25	210±25
d (mm)	M12	M16	M16	M20
s (mm)	6	8	10	12

Adjustable mounting assembly, parallel/vertical to I-Beam

.Z35

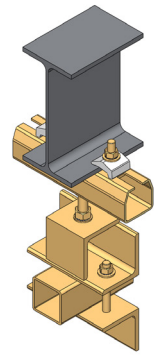

NIKO Profile No.	24.000	25.000	26.000	27.000
Bracket No. for IPN 80 (IPE 80)	24.Z35.080			
Bracket No. for IPN 100 (IPE 80)	24.Z35.100	25.Z35.100		
Bracket No. for IPN 120 (IPE 100)	24.Z35.120	25.Z35.120		
Bracket No. for IPN 140 (IPE 120)	24.Z35.140	25.Z35.140		
Bracket No. for IPN 160 (IPE 140)	24.Z35.160	25.Z35.160	26.Z35.160	27.Z35.160
Bracket No. for IPN 180 (IPE 160)	24.Z35.180	25.Z35.180	26.Z35.180	27.Z35.180
Bracket No. for IPN 200 (IPE 180)	24.Z35.200	25.Z35.200	26.Z35.200	27.Z35.200
Bracket No. for IPN 220 (IPE 200)		25.Z35.220	26.Z35.220	27.Z35.220
Bracket No. for IPN 240 (IPE 220)		25.Z35.240	26.Z35.240	27.Z35.240
Bracket No. for IPN 260 (IPE 240)		25.Z35.260	26.Z35.260	27.Z35.260
B (mm)	50	60	80	100
d (mm)	M16	M20	M20	M30
H (mm)	210	240	275	340

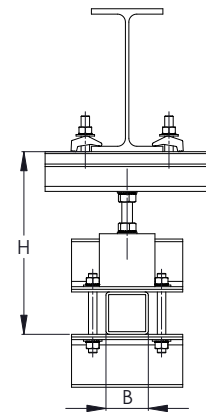
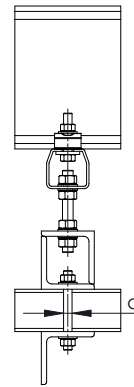

LIGHT CRANE SYSTEMS

Angle adjustable mounting assembly with bracket .B04 for I-Beam

.Z27

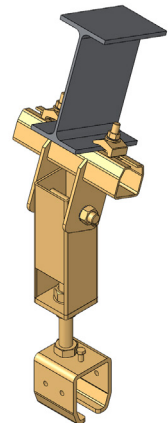

NIKO Profile No.	24.000	25.000	26.000	27.000
Bracket No. for IPN 80 (IPE 80)	24.Z27.080			
Bracket No. for IPN 100 (IPE 80)	24.Z27.100	25.Z27.100		
Bracket No. for IPN 120 (IPE 100)	24.Z27.120	25.Z27.120		
Bracket No. for IPN 140 (IPE 120)	24.Z27.140	25.Z27.140		
Bracket No. for IPN 160 (IPE 140)	24.Z27.160	25.Z27.160	26.Z27.160	27.Z27.160
Bracket No. for IPN 180 (IPE 160)	24.Z27.180	25.Z27.180	26.Z27.180	27.Z27.180
Bracket No. for IPN 200 (IPE 180)	24.Z27.200	25.Z27.200	26.Z27.200	27.Z27.200
Bracket No. for IPN 220 (IPE 200)		25.Z27.220	26.Z27.220	27.Z27.220
Bracket No. for IPN 240 (IPE 220)		25.Z27.240	26.Z27.240	27.Z27.240
Bracket No. for IPN 260 (IPE 240)		25.Z27.260	26.Z27.260	27.Z27.260
B (mm)	61	81	100	116
L (mm)	68	90	110	120
H max (mm)	3000	3000	3000	3000

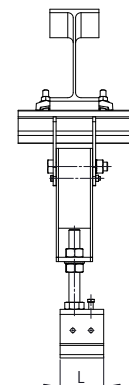
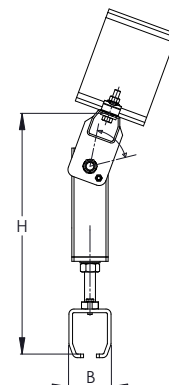

Light crane systems

We reserve the right for technical amendments without obligation.
The product pictures and drawings depicted in this catalogue
do not always reflect all available sizes.

Version January 2018

www.niko.eu.com

Angle adjustable mounting assembly with support joint .B11 for I-Beam

.Z28

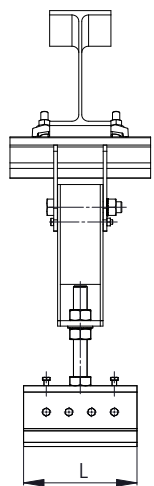
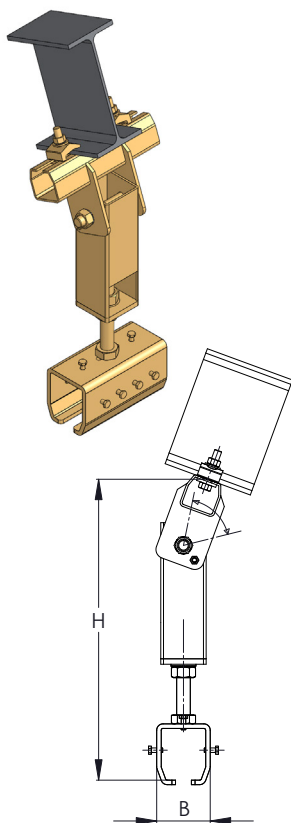

NIKO Profile No.	24.000	25.000	26.000	27.000
Bracket No. for IPN 80 (IPE 80)	24.Z28.080			
Bracket No. for IPN 100 (IPE 80)	24.Z28.100	25.Z28.100		
Bracket No. for IPN 120 (IPE 100)	24.Z28.120	25.Z28.120		
Bracket No. for IPN 140 (IPE 120)	24.Z28.140	25.Z28.140		
Bracket No. for IPN 160 (IPE 140)	24.Z28.160	25.Z28.160	26.Z28.160	27.Z28.160
Bracket No. for IPN 180 (IPE 160)	24.Z28.180	25.Z28.180	26.Z28.180	27.Z28.180
Bracket No. for IPN 200 (IPE 180)	24.Z28.200	25.Z28.200	26.Z28.200	27.Z28.200
Bracket No. for IPN 220 (IPE 200)		25.Z28.220	26.Z28.220	27.Z28.220
Bracket No. for IPN 240 (IPE 220)		25.Z28.240	26.Z28.240	27.Z28.240
Bracket No. for IPN 260 (IPE 240)		25.Z28.260	26.Z28.260	27.Z28.260
B (mm)	61	81	100	116
L (mm)	150	180	200	250
H max (mm)	3000	3000	3000	3000

LIGHT CRANE SYSTEMS

Ceiling mounting assembly

.Z25

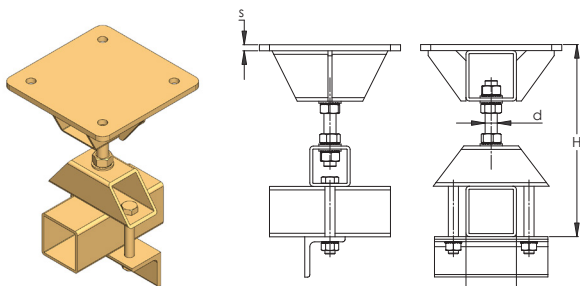

NIKO Profile No.	24.000	25.000	26.000	27.000
Part No.	24.Z25	25.Z25	26.Z25	27.Z25
B (mm)	50	60	80	100
s (mm)	6	8	10	12
d (mm)	M16	M20	M20	M30
H (mm)	240	270	300	350

Ceiling mounting assembly for load 2.000kg

.Z26

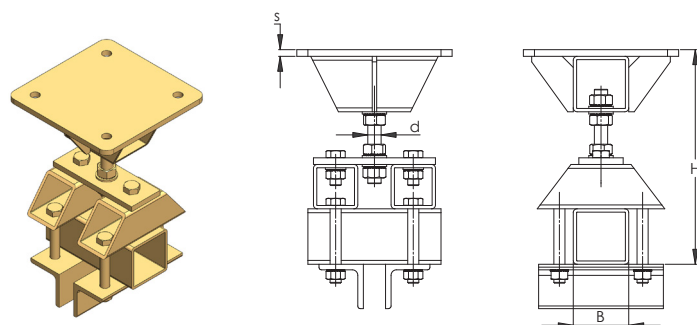

NIKO Profile No.	27.000
Part No.	27.Z26
B (mm)	100
s (mm)	15
d (mm)	M36
H (mm)	350

Connection kit for reinforced tracks with welded square profiles

.Z45

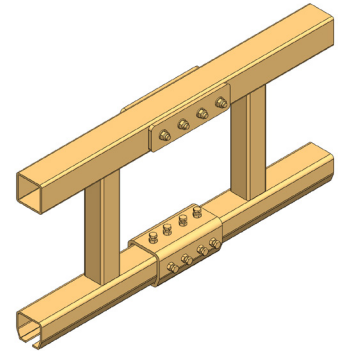
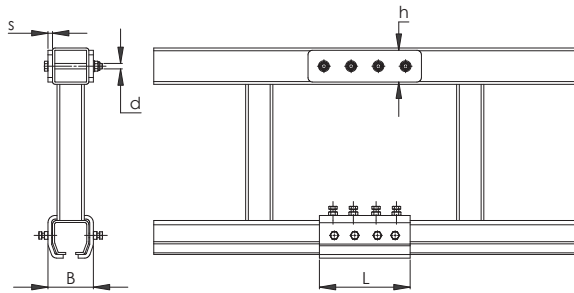

NIKO Profile No.	24.000	25.000	26.000	27.000
Part No.	24.Z45	25.Z45	26.Z45	27.Z45
B (mm)	61	81	100	116
L (mm)	150	180	200	250
h (mm)	40	50	70	90
s (mm)	6	8	10	12
d (mm)	M10	M10	M12	M16

NIKO Bearings Options

	NIKO-Profile	21.	23.	24.	25.	26.	27.
	Low temperature bearings (special grease) for operating temperatures from -50°C to 80°C		TL.23	TL.24	TL.25	TL.26	TL.27
	High temperature bearings (special grease) for operating temperatures from -40°C to 260°C		TH.23	TH.24	TH.25	TH.26	TH.27
	Nylon tyred bearings		PL.23	PL.24	PL.25	PL.26	PL.27
	Heavy duty polyamide tyred bearings		PLN.23	PLN.24	PLN.25	PLN.26	PLN.27
	Ammonia resistant bearings (special grease) for operating temperatures from -20°C to 130°C	AM.21	AM.23	AM.24	AM.25	AM.26	AM.27
	Stainless steel bearings for operating temperatures from -20°C to 80°C	IN.21	IN.23	IN.24	IN.25		
	Phosphor bronze tyred bearing		PB.23	PB.24	PB.25	PB.26	PB.27

Light crane systems

We reserve the right for technical amendments without obligation.
The product pictures and drawings depicted in this catalogue do not always reflect all available sizes.

4-Wheel trolley with a rotating eye DIN 582

.T40

This trolley is suitable for hoists with hook suspension.

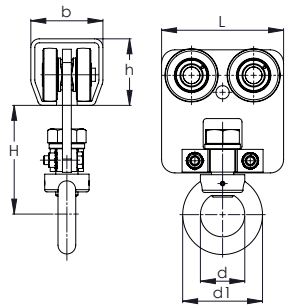
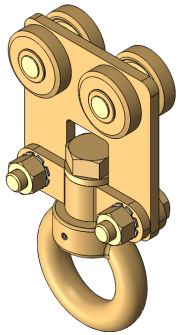

NIKO Profile No.	23.000	24.000	25.000	26.000	27.000
Part No.	23.T40	24.T40	25.T40	26.T40	27.T40
SWL Kg	40	80	200	400	800
b (mm)	40	48.5	65	80	90
H (mm)	74	82	98	126	165
L (mm)	68	90	110	150	200
d1 (mm)	54	63	72	90	108
h (mm)	35	43.5	60	75	110
d (mm)	30	35	40	50	60

4-Wheel trolley with clevis pin and buffer (plate)

.T48

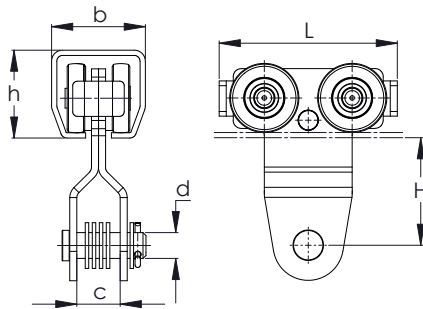
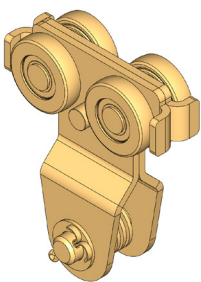

NIKO Profile No.	24.000	25.000	26.000	27.000
Part No.	24.T48	25.T48	26.T48	27.T48
SWL Kg	125	250	500	1000
L (mm)	100	130	152	215
H (mm)	65	77	94	123
b (mm)	48.5	65	80	90
h (mm)	43.5	60	75	110
d (mm)	16	20	22	26
c (mm)	30	37	37	45

*Only for straight sections. Not to be used in switches or bends.

Heavy duty hoist trolley

.T49

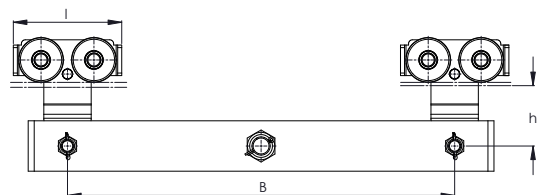
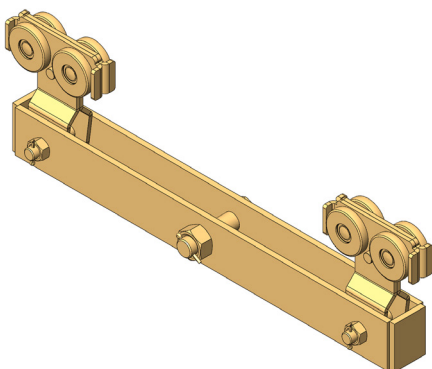

NIKO Profile No.	24.000	25.000	26.000	27.000
Part No.	24.T49	25.T49	26.T49	27.T49
SWL Kg	250	500	1000	2000
l (mm)	100	130	152	215
h (mm)	65	77	94	123
B (mm)	300	418	500	768

Load carrier (flight bar) with eye and rotating eye (2 x .T14 trolley)

.T24/.T26

This trolley is suitable for increased load applications.

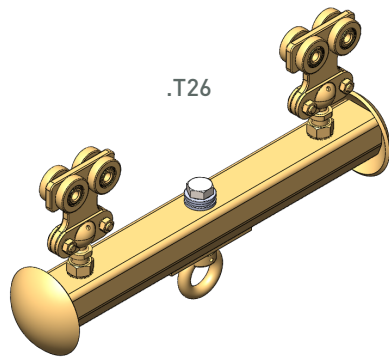

.T26

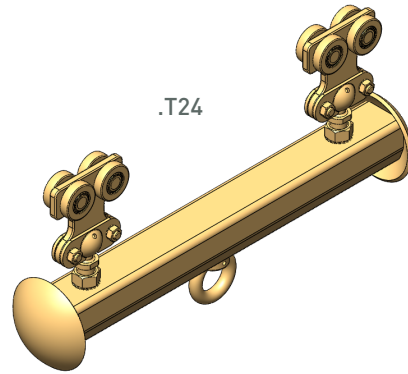

.T24

NIKO Profile No.	23.000	24.000	25.000	26.000	27.000
Part No.	23.T24	24.T24	25.T24	26.T24	27.T24
Part No.	23.T26	24.T26	25.T26	26.T26	27.T26
SWL Kg	80	160	400	800	1600
H (mm) .T24	128	152	190	250	310
H (mm) .T26	133	160	200	260	320
h (mm)	35	43.5	60	75	110
b (mm)	40	48.5	65	80	90
B (mm)	180	300	420	500	700
L (mm)	300	450	600	700	1000
d (mm)	30	35	40	50	60

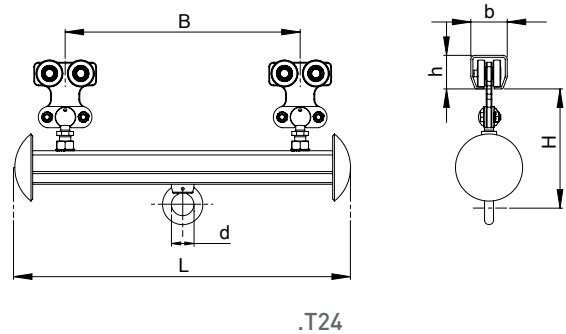

.T24

LIGHT CRANE SYSTEMS

End carriage with track joint

.T54/.T74

This range of trolleys is fitted with horizontal guide rollers and are used for connecting the bridge crane to the long travel tracks.

For standard crane applications it is recommended that only one end carriage is fixed on the crane bridge allowing the other to move freely and compensate for track misalignment.

For bridge length over 6 meters, longer end carriages are used (.T54L/.T74L)

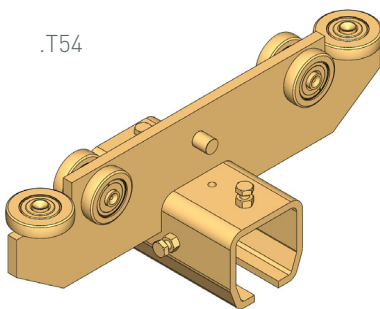

.T54

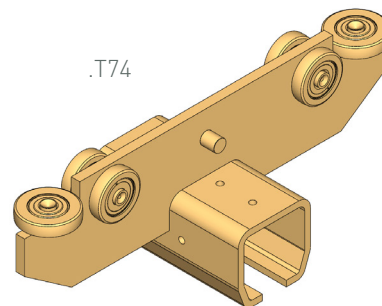

.T74

NIKO Profile No.	23.000	24.000	25.000	26.000	27.000
Part No.	23.T54	24.T54	25.T54	26.T54	27.T54
Part No.	23.T74	24.T74	25.T74	26.T74	27.T74
Load up to (kg)	50	125	250	500	1000
L (mm)	350	400	450	500	600
L1 (mm)	242	270	276	280	340
L5 (mm)	40	50	60	70	100
H (mm)	52	63	91	106	163
h1 (mm)	0.5	2	3.5	5	5.5

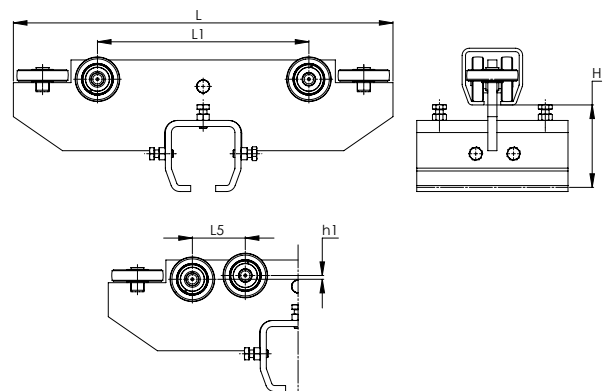

Light crane systems

We reserve the right for technical amendments without obligation.
The product pictures and drawings depicted in this catalogue do not always reflect all available sizes.

End carriage with double track joint

.T53/.T73

We can supply double carriages for overhead cranes for suspending two NIKO rails.

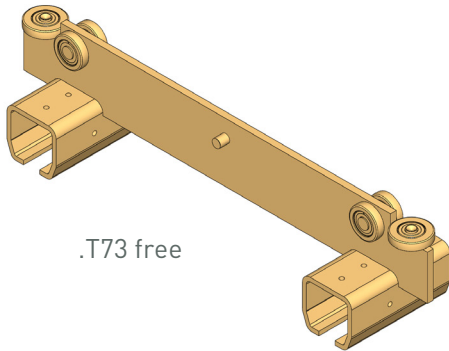

.T73 free

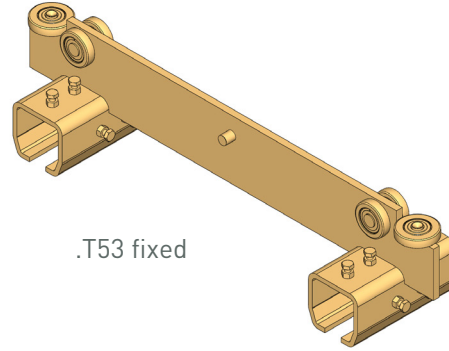

.T53 fixed

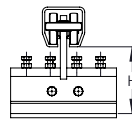
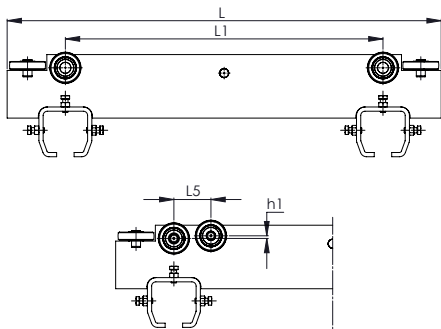

NIKO Profile No.	23.000	24.000	25.000	26.000	27.000
Part No.	23.T53	24.T53	25.T53	26.T53	27.T53
Part No.	23.T73	24.T73	25.T73	26.T73	27.T73
Load up to (kg)	50	125	250	500	1000
L (mm)	410	630	700	820	860
L1 (mm)	300	495	500	600	600
L5 (mm)	40	50	60	70	100
H (mm)	64	74	91	126	153
h1 (mm)	0.5	2	3.5	5	5.5

Heavy duty end carriage trolley

.T58/.T78

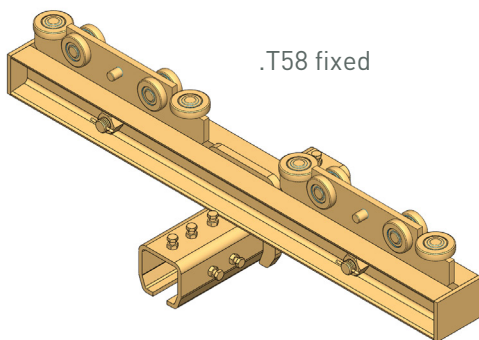

.T58 fixed

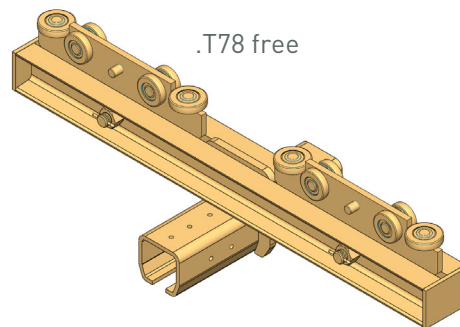

.T78 free

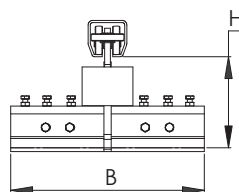
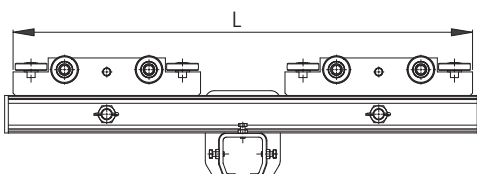

NIKO Profile No.	25.000	26.000	27.000
Part No.	25.T58	26.T58	27.T58
Part No.	25.T78	26.T78	27.T78
Load up to (kg)	500	1000	2000
B (mm)	360	400	500
H (mm)	138	188	278
L (mm)	950	980	1420

End carriage plate-short

For bridge length over 6 meters, longer end carriages are used (.T52L)

.T52

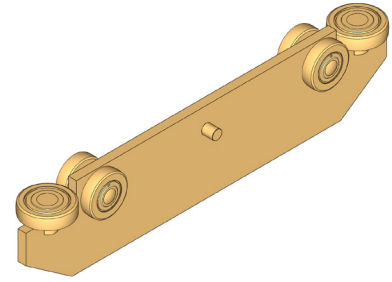

NIKO Profile No.	23.000	24.000	25.000	26.000	27.000
Part No.	23.T52	24.T52	25.T52	26.T52	27.T52
Load up to (kg)	50	125	250	500	1000
L (mm)	350	400	450	500	600
L1 (mm)	242	270	276	280	340
L5 (mm)	40	50	60	70	100
H (mm)	23	35	52	60	59
h1 (mm)	0.5	2	3.5	5	5.5

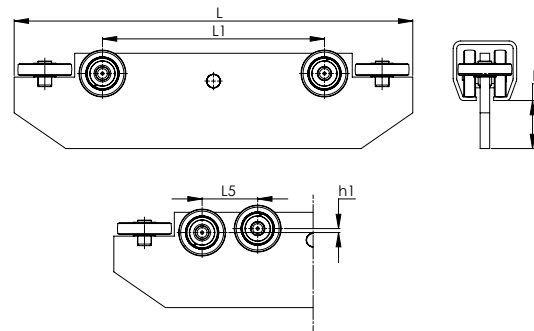

LIGHT CRANE SYSTEMS

End carriage with flat plate

For bridge length over 6 meters, longer end carriages are used (.T51L)

.T51

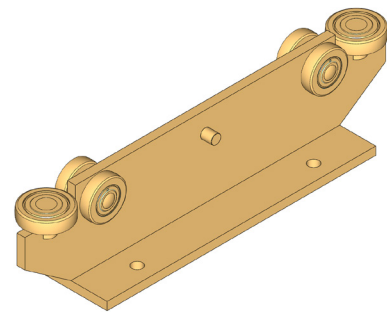

NIKO Profile No.	23.000	24.000	25.000	26.000	27.000
Part No.	23.T51	24.T51	25.T51	26.T51	27.T51
Load up to (kg)	50	125	250	500	1000
L (mm)	350	400	450	500	600
L1 (mm)	242	270	276	280	340
L2 (mm)	200	220	220	260	300
L3 (mm)	290	315	335	370	440
B (mm)	60	70	100	120	150
B1 (mm)	36	46	60	80	100
d (mm)	8.5	11	13	17	21
L5 (mm)	40	50	60	70	100
H (mm)	31	42	62	72	74
h1 (mm)	0.5	2	3.5	5	5.5

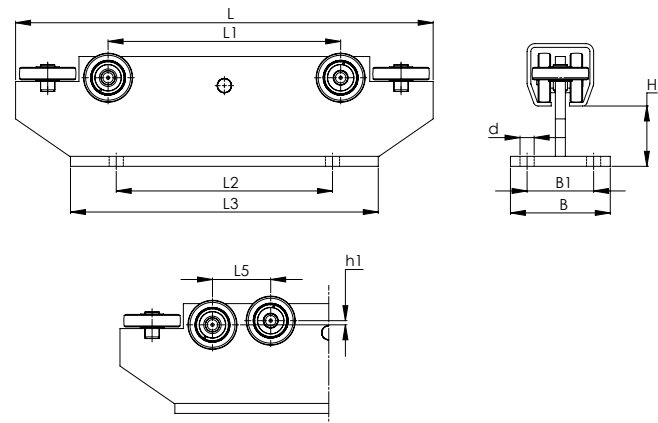

Light crane systems

We reserve the right for technical amendments without obligation.
The product pictures and drawings depicted in this catalogue do not always reflect all available sizes.

Version January 2018

www.niko.eu.com

51

End carriage with flat plate-short

.T56

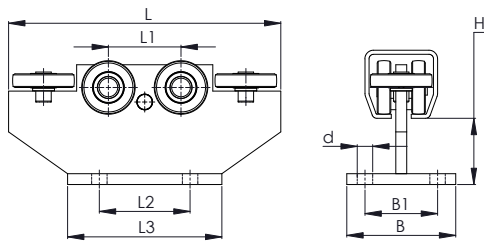
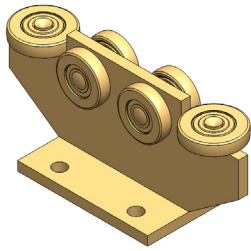

NIKO Profile No.	23.000	24.000	25.000	26.000	27.000
Part No.	23.T56	24.T56	25.T56	26.T56	27.T56
L (mm)	150	180	230	300	370
L1 (mm)	40	50	59	80	110
B (mm)	60	70	100	120	150
B1 (mm)	36	46	60	80	100
d (mm)	8.5	11	13	17	21
H (mm)	31	42	62	72	74
L2 (mm)	55	55	90	100	150
L3 (mm)	95	95	150	170	210

End carriage with rotating track joint

.T55

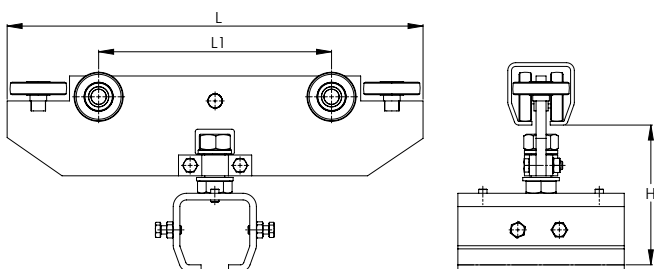
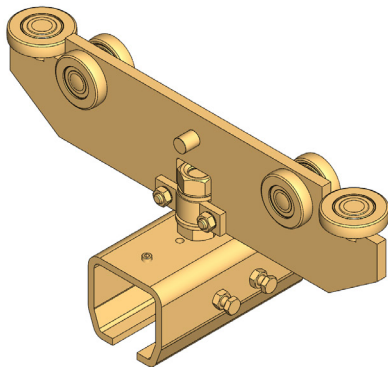

NIKO Profile No.	23.000	24.000	25.000	26.000	27.000
Part No.	23.T55	24.T55	25.T55	26.T55	27.T55
L (mm)	350	400	450	500	600
L1 (mm)	242	270	276	280	340
H (mm)	94	99	136	168	240

Low headroom assembly for adjusting end carriages

.T111

End carriages are not included.

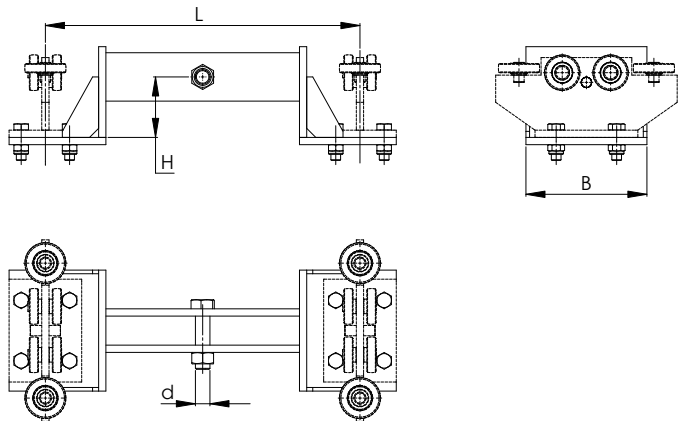
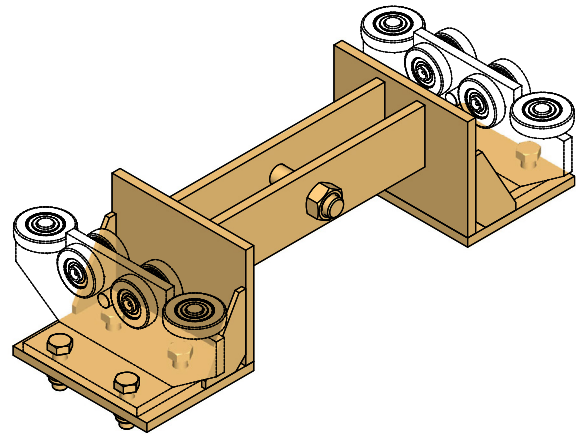

NIKO Profile No.	24.000	25.000	26.000	27.000
Part No.	24.T111	25.T111	26.T111	27.T111
B (mm)	120	180	200	250
L (mm)	420	470	520	620
H (mm)	60	80	100	140
d (mm)	20	24	24	36

Corner plate with joint for end carriage

.T98

End carriages are not included.

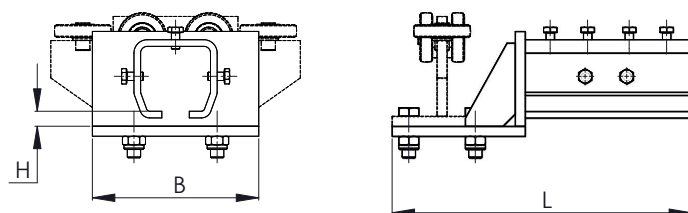
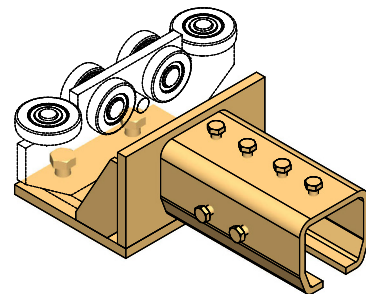

NIKO Profile No.	24.000	25.000	26.000	27.000
Part No.	24.T98	25.T98	26.T98	27.T98
B (mm)	120	180	200	250
L (mm)	220	310	360	450
H (mm)	15	16	18	20

Light crane systems

We reserve the right for technical amendments without obligation.
The product pictures and drawings depicted in this catalogue do not always reflect all available sizes.

Bridge Interlock (Part 1) (safety plate must be installed)

.H01

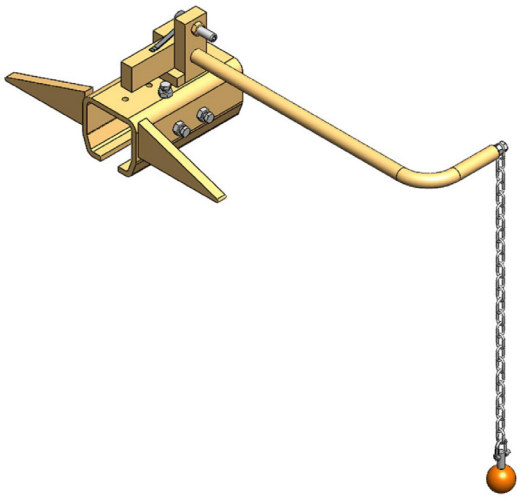

NIKO Profile No.	23.000	24.000	25.000	26.000	27.000
Part No.	23.H01	24.H01	25.H01	26.H01	27.H01
a (mm)	50	61	81	100	116
h (mm)	44	54	75	94	133
l (mm)	120	150	180	200	250
H (mm)	117	126	170	188	229

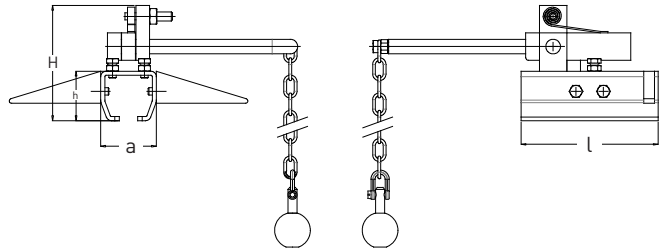

Bridge Interlock (Part 2) (safety plate must be installed)

.H02

LIGHT CRANE SYSTEMS

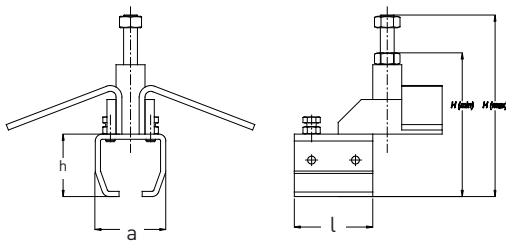
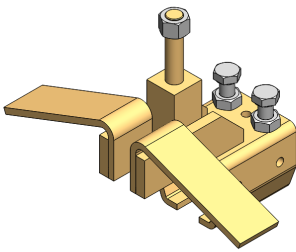

NIKO Profile No.	23.000	24.000	25.000	26.000	27.000
Part No.	23.H02	24.H02	25.H02	26.H02	27.H02
a (mm)	50	61	81	100	116
h (mm)	44	54	75	94	133
l (mm)	56	68	90	110	120
H min (mm)	121	130	168	186	291
H max (mm)	147	156	209	227	359

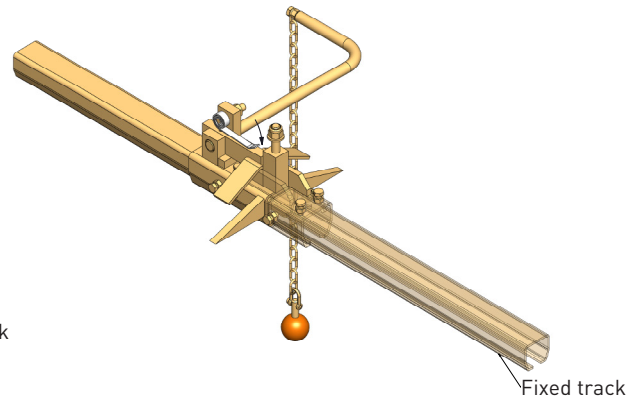
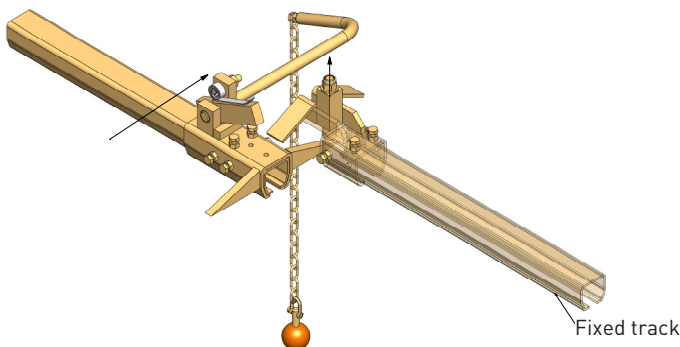

Track transfer assembly (Part 1) (no safety plate required)

.H21

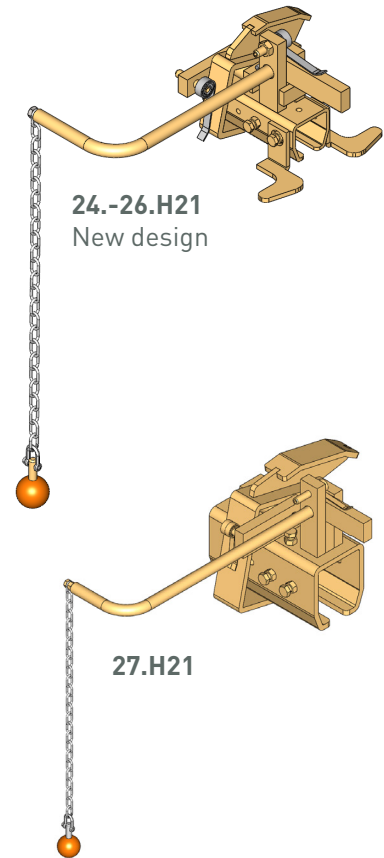
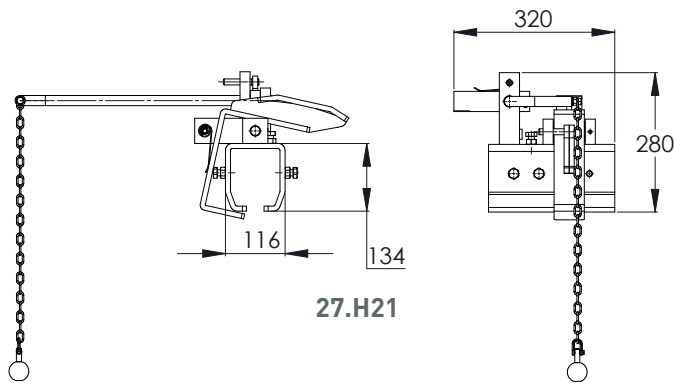

Track transfer assembly (Part 2) (no safety plate required)

.H22

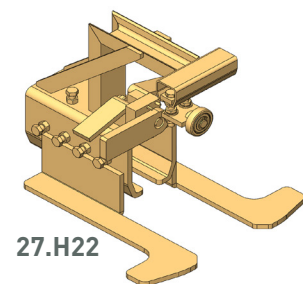
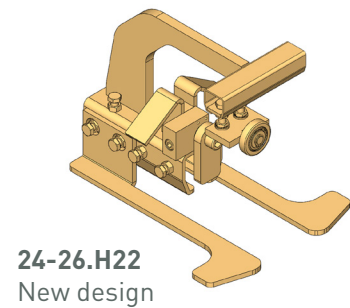
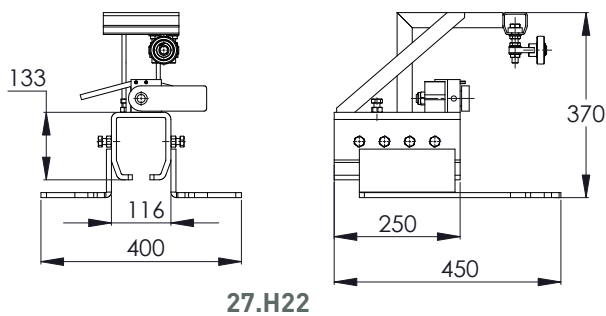

Track end stop

.X01

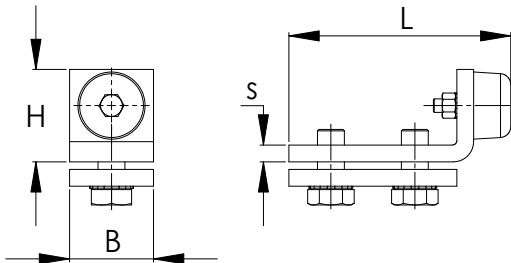
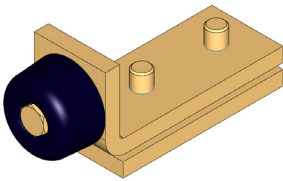

NIKO Profile No.	23.000	24.000	25.000	26./27.000
Part No.	23.X01	24.X01	25.X01	26.X01
L (mm)	70	75	120	135
B (mm)	20	30	40	50
H (mm)	24	30	47	55
s (mm)	4	5	8	10

Safety bolt for track end stop with track punching

.X06

(Track end stop not included)

LIGHT CRANE SYSTEMS

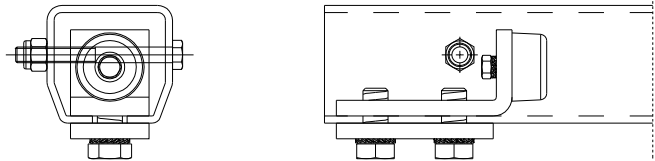
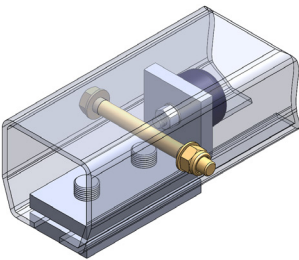

NIKO Profile No.	24.000	25.000	26.000	27.000
Part No.	24.X06	25.X06	26.X06	27.X06

Track end stop (safety bolt with rubber)

.X11

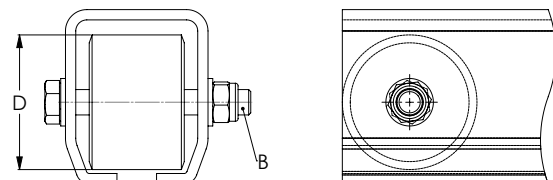
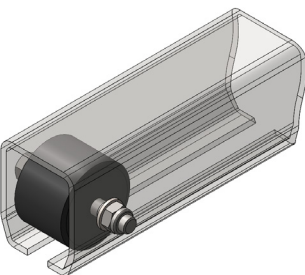

NIKO Profile No.	25.000	26.000	27.000
Part No.	25.X11	26.X11	27.X11
D (mm)	40	50	80
B (mm)	M8	M12	M16

Cable end clamp

.K00

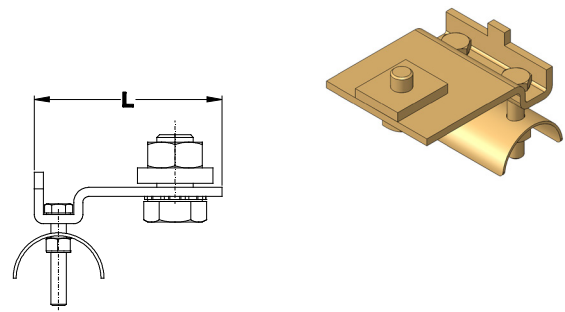

NIKO Profile No.	23.000	24.000	25.000	26.000	27.000
Part No.	23.K00	24.K00	25.K00	26.K00	27.K00
L (mm)	57	57	57	57	57

Cable trolley (nylon)

.L00

This trolley is used for carrying flat cable for electrical power supply and can be adapted for hoses and round cables.

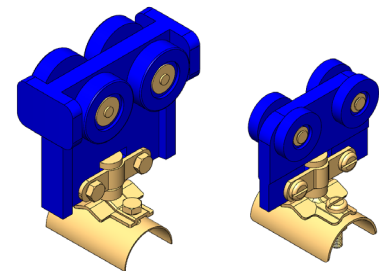
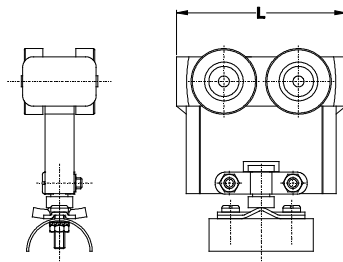

25.-27.L00

23.L00

NIKO Profile No.	21.000	23.000	24.000	25.000	26.000	27.000
Part No.	23.L00		25.L00		27.L00	
For cable dimensions	flat up to 23x10mm & round up to 15mm diameter		flat up to 23x10mm & round up to 15mm diameter		flat up to 23x10mm & round up to 15mm diameter	
L (mm)	60		78		78	

LIGHT CRANE SYSTEMS

Cable trolley (nylon)

.L01

This trolley is used for carrying flat cable for electrical power supply.

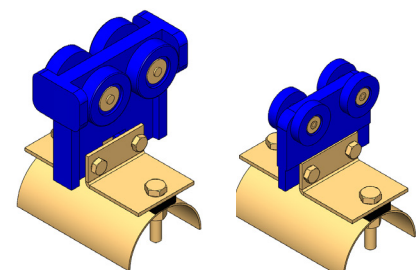
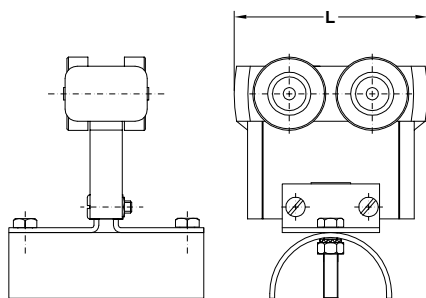

25.-27.L01

23.L01

NIKO Profile No.	21.000	23.000	24.000	25.000	26.000	27.000
Part No.	23.L01		25.L01		27.L01	
For cable dimensions	flat up to 55x20mm		flat up to 55x20mm		flat up to 55x20mm	
L (mm)	60		78		78	

Light crane systems

We reserve the right for technical amendments without obligation.
The product pictures and drawings depicted in this catalogue
do not always reflect all available sizes.

Version January 2018

www.niko.eu.com

57

NIKO Track Profiles, stainless steel

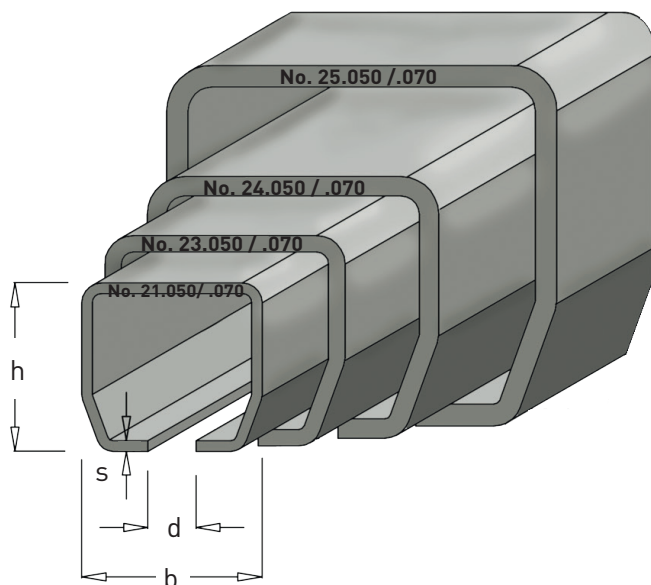

NIKO Profile No.	Dimensions			
	h (mm)	b (mm)	d (mm)	s (mm)
21.050 Stainless steel (304)	28.00	30.00	8.00	1.75
21.070 Stainless steel (316)	28.00	30.00	8.00	1.75
23.050 Stainless steel (304)	35.00	40.00	11.00	2.75
23.070 Stainless steel (316)	35.00	40.00	11.00	2.75
24.050 Stainless steel (304)	43.50	48.50	15.00	3.20
24.070 Stainless steel (316)	43.50	48.50	15.00	3.00
25.050 Stainless steel (304)	60.00	65.00	18.00	4.00
25.070 Stainless steel (316)	60.00	65.00	18.00	4.00

LIGHT CRANE SYSTEMS

Reinforced track with welded steel plate .030

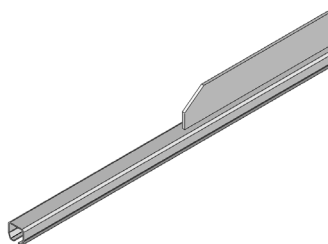

NIKO Profile No.	23.050/.070	24.050/.070	25.050/.070
Part No. (304)	53.030	54.030	55.030
Part No. (316)	73.030	74.030	75.030

See product dimensions in page 29.

Reinforced track with welded rectangular tube .080

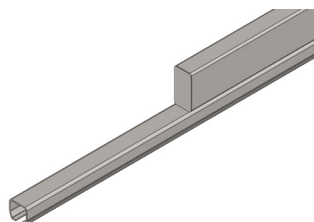

NIKO Profile No.	24.050/.070	25.050/.070
Part No. (304)	54.080	55.080
Part No. (316)	74.080	75.080

See product dimensions in page 29.

Reinforced track with welded square profiles .045

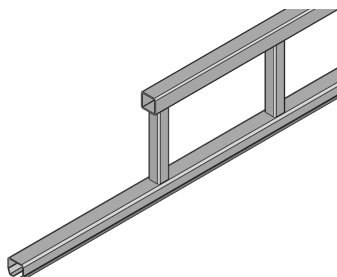

NIKO Profile No.	24.050/.070	25.050/.070
Part No. (304)	54.045	55.045
Part No. (316)	74.045	75.045

See product dimensions in page 29.

Splice joint

.B49

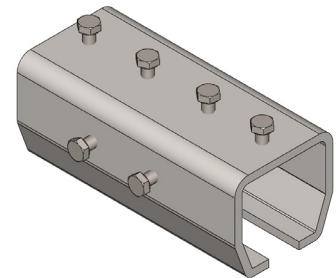

NIKO Profile No.	21.050/.070	23.050/.070	24.050/.070	25.050/.070
Part No. (304)	51.B49	53.B49	54.B49	55.B49
Part No. (316)	71.B49	73.B49	74.B49	75.B49

See product dimensions in page 30.

Support bracket

.B00

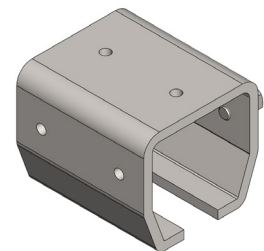

NIKO Profile No.	21.050/.070	23.050/.070	24.050/.070	25.050/.070
Part No. (304)	51.B00	53.B00	54.B00	55.B00
Part No. (316)	71.B00	73.B00	74.B00	75.B00

See product dimensions in page 26.

LIGHT CRANE SYSTEMS

Ceiling support bracket

.B02

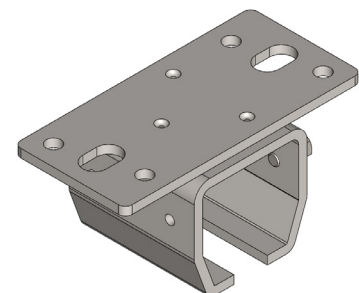

NIKO Profile No.	21.050/.070	23.050/.070	24.050/.070	25.050/.070
Part No. (304)	51.B02	53.B02	54.B02	55.B02
Part No. (316)	71.B02	73.B02	74.B02	75.B02

See product dimensions in page 26.

Light crane systems

We reserve the right for technical amendments without obligation.
The product pictures and drawings depicted in this catalogue do not always reflect all available sizes.

Split support bracket

.B03

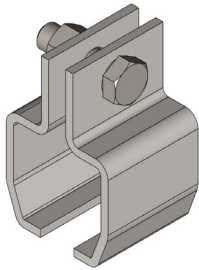

STAINLESS
STEEL
304

STAINLESS
STEEL
316

NIKO Profile No.	24.050/.070	25.050/.070
Part No. (304)	54.B03	55.B03
Part No. (316)	74.B03	75.B03

See product dimensions in page 31.

Adjustable bracket

.B04

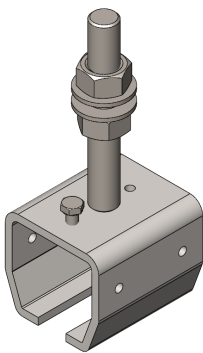

STAINLESS
STEEL
304

STAINLESS
STEEL
316

NIKO Profile No.	21.050/.070	23.050/.070	24.050/.070	25.050/.070
Part No. (304)	51.B04	53.B04	54.B04	55.B04
Part No. (316)	71.B04	73.B04	74.B04	75.B04

See product dimensions in page 31.

4-wheel trolley with a rotating eye DIN 582

.T40

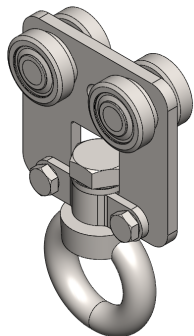

STAINLESS
STEEL
304

STAINLESS
STEEL
316

NIKO Profile No.	23.050/.070	24.050/.070	25.050/.070
Part No. (304)	53.T40	54.T40	55.T40
Part No. (316)	73.T40	74.T40	75.T40

See product dimensions in page 48.

4-wheel trolley with clevis pin and buffer (plate)

.T48

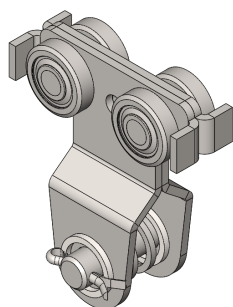

STAINLESS
STEEL
304

STAINLESS
STEEL
316

NIKO Profile No.	24.050/.070	25.050/.070
Part No. (304)	54.T48	55.T48
Part No. (316)	74.T48	75.T48

See product dimensions in page 48.

Load carrier (flight bar) with eye & rotating eye (2x.T14 trolley)

.T24



NIKO Profile No.	21.050/.070	23.050/.070	24.050/.070	25.050/.070
Part No. (304)	51.T24	53.T24	54.T24	55.T24
Part No. (304)	51.T26	53.T26	54.T26	55.T26
Part No. (316)	71.T24	73.T24	74.T24	75.T24
Part No. (316)	71.T26	73.T26	74.T26	75.T26

See product dimensions in page 49.

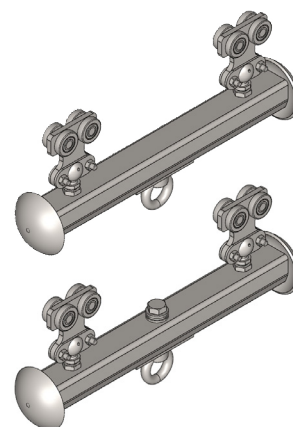

End carriage with flat plate

.T51



NIKO Profile No.	21.050/.070	23.050/.070	24.050/.070	25.050/.070
Part No. (304)	51.T51	53.T51	54.T51	55.T51
Part No. (316)	71.T51	73.T51	74.T51	75.T51

See product dimensions in page 51.

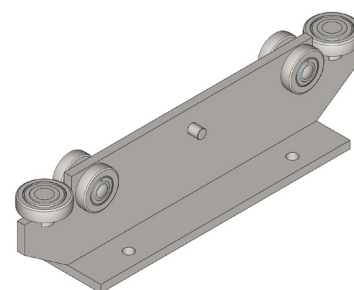

End carriage

.T52



NIKO Profile No.	21.050/.070	23.050/.070	24.050/.070	25.050/.070
Part No. (304)	51.T52	53.T52	54.T52	55.T52
Part No. (316)	71.T52	73.T52	74.T52	75.T52

See product dimensions in page 51.

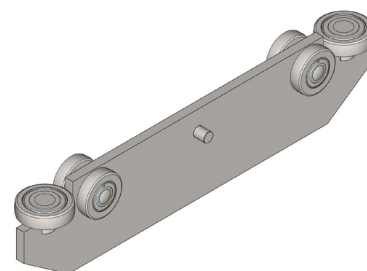

LIGHT CRANE SYSTEMS

Heavy duty hoist trolley

.T49



NIKO Profile No.	24.050/.070	25.050/.070
Part No. (304)	54.T49	55.T49
Part No. (316)	74.T49	75.T49

See product dimensions in page 48.

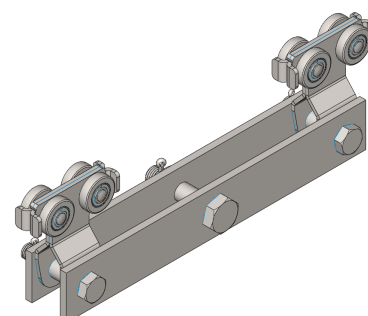

Light crane systems

We reserve the right for technical amendments without obligation.
The product pictures and drawings depicted in this catalogue do not always reflect all available sizes.

End carriage with track joint (fixed)

.T54/.T74

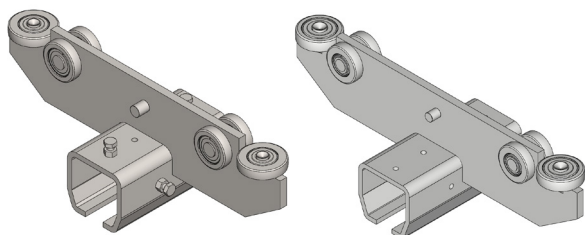

.T54

.T74



NIKO Profile No.	23.050/.070	24.050/.070	25.050/.070
Part No. [304]	53.T54/.T74	54.T54/.T74	55.T54/.T74
Part No. [316]	73.T54/.T74	74.T54/.T74	75.T54/.T74

See product dimensions in page 49.

Track end stop

.X01

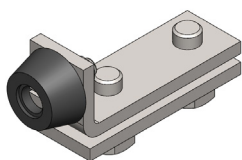

NIKO Profile No.	23.050/.070	24.050/.070	25.050/.070
Part No. [304]	53.X01	54.X01	55.X01
Part No. [316]	73.X01	74.X01	75.X01

See product dimensions in page 56.

Cable trolley (nylon)

.L01

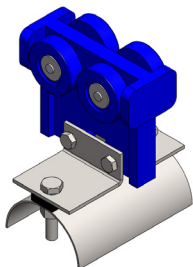

NIKO Profile No.	21.-23.050 / 21.-23.070	24.-25.050 / 24.-25.070
Part No. [304]	53.L01	55.L01
Part No. [316]	73.L01	75.L01

See product dimensions in page 57.

Cable and clamp

.K00

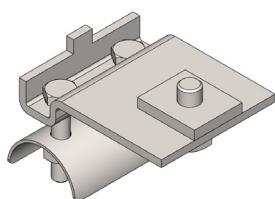

NIKO Profile No.	23.050/.070	24.050/.070	25.050/.070
Part No. [304]	53.K00	54.K00	55.K00
Part No. [316]	73.K00	74.K00	75.K00

See product dimensions in page 57.

Our quality control department is manned by experienced and highly skilled engineers. Our test lab is equipped with endurance test stands, tensile stress equipment, hardness test machines and other laboratory equipment. Virtual stress analysis is also performed during the developing phase of every component.

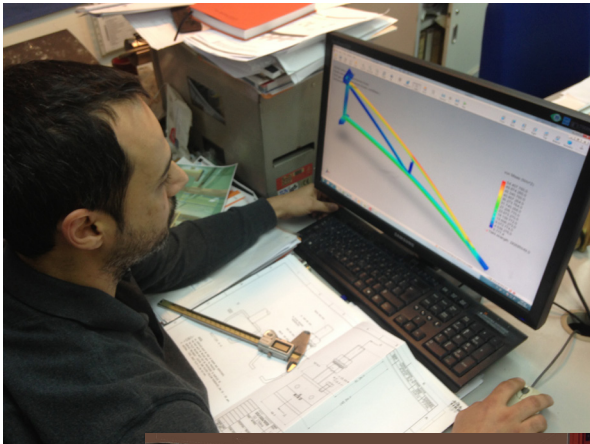

LIGHT CRANE SYSTEMS

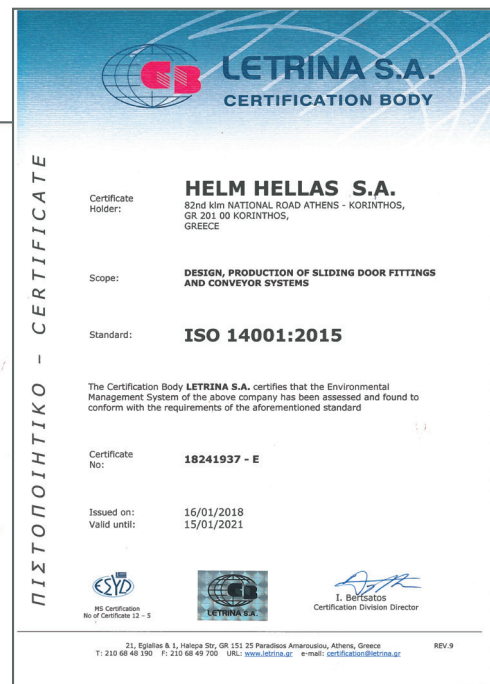

Light crane systems

We reserve the right for technical amendments without obligation. The product pictures and drawings depicted in this catalogue do not always reflect all available sizes.



AUSTRIA-NIKO Vertriebs GmbH
 Hainfelder Strasse 48
 A - 2560 Berndorf
 Tel. 0043 2672-21201
 Fax 0043 2672-21201-13
office.at@niko.eu.com
www.niko.world

CHINA-NIKO TRADING (SHANGHAI) Co., Ltd
 Room 605, Building #13, No.354
 Linghe Road, Pudong District,
 P.R.China - 200120 Shanghai
 Tel. 0086 139 1814 5645
info.cn@niko.eu.com

GERMANY-NIKO Technik GmbH
 Robert-Bosch-Str. 14
 DE - 42489 Wülfrath
 Tel. 0049 (0) 2058 9093603
 Fax 0049 (0) 2058 9093604
office.de@niko.eu.com

GREECE-Helm Hellas S.A.
 82nd Km Athens-Korinthos
 P.O. Box 209
 GR - 201 00 KORINTHOS
 Tel. 0030 27410 76800
 Fax 0030 27410 25368
info@niko.eu.com

POLAND- NIKO Polska
 Wojska Polskiego 65A
 PL - Wielun 98-300
 Tel. 0048 504 00 35 56
info.pl@niko.eu.com

UNITED KINGDOM-NIKO Ltd
 Units 15-21, Insight Park
 Welsh Road East, Southam
 Warwickshire, CV47 1NE -UK
 Tel. 0044 (0) 1926 813111
 Fax 0044 (0) 1926 815599
Sales@niko.co.uk
www.niko.co.uk

USA-NIKO Track
 300 Highpoint Ave
 USA - Portsmouth, RI. 02871
 Tel. 001 (0) 401 683 7525
 Fax 001 (0) 401 293 3848
info@nikotrack.com
www.nikotrack.com

Copyright NIKO (Version January 2018)
 We take no obligation for layout, composition, technical modifications as well as misprints.
 Subject to technical modifications / Images can be differ from original.

www.niko.eu.com www.niko.co.uk www.nikotrack.com www.niko.world

Your **NIKO** agent will be happy to advise you:



Complete product range **NIKO**:

- Light duty sliding door hardware
- Heavy duty sliding door hardware
- Conveyor systems
- Light cranes
- Cable trolleys, festoon systems & conductor bars
- Personal fall arrest systems (EN 795)
- Accessories for gates and doors